

**PacketCable™**

**Residential SIP Telephony Provisioning,  
Activation, Configuration and Management  
Specification**

**PKT-SP-RST-PACM-I01-060927**

**ISSUED**

**Notice**

This PacketCable specification is a cooperative effort undertaken at the direction of Cable Television Laboratories, Inc. (CableLabs®) for the benefit of the cable industry. Neither CableLabs, nor any other entity participating in the creation of this document, is responsible for any liability of any nature whatsoever resulting from or arising out of use or reliance upon this document by any party. This document is furnished on an AS-IS basis and neither CableLabs, nor other participating entity, provides any representation or warranty, express or implied, regarding its accuracy, completeness, or fitness for a particular purpose.

© Copyright 2006 Cable Television Laboratories, Inc.  
All rights reserved.

## Document Status Sheet

<b>Document Control Number:</b>	PKT-SP-RST-PACM-I01-060927			
<b>Document Title:</b>	Residential SIP Telephony Provisioning, Activation, Configuration and Management Specification			
<b>Revision History:</b>	I01 – Released 09/27/2006			
<b>Date:</b>	September 27, 2006			
<b>Status:</b>	<del>Work in Progress</del>	<del>Draft</del>	<b>Issued</b>	<del>Closed</del>
<b>Distribution Restrictions:</b>	<del>Author Only</del>	<del>CL/Member</del>	<del>CL/Member/Vendor</del>	<b>Public</b>

### Key to Document Status Codes:

- Work in Progress** An incomplete document, designed to guide discussion and generate feedback, that may include several alternative requirements for consideration.
- Draft** A document in specification format considered largely complete, but lacking review by Members and vendors. Drafts are susceptible to substantial change during the review process.
- Issued** A stable document, which has undergone rigorous member and vendor review and is suitable for product design and development, cross-vendor interoperability, and for certification testing.
- Closed** A static document, reviewed, tested, validated, and closed to further engineering change requests to the specification through CableLabs.

### Trademarks:

DOCSIS®, eDOCSIS™, PacketCable™, CableHome®, CableOffice™, OpenCable™, OCAP™, CableCARD™, M-CMTS™, and CableLabs® are trademarks of Cable Television Laboratories, Inc.

# Contents

<b>1</b>	<b>SCOPE</b> .....	<b>1</b>
1.1	Introduction and Purpose.....	1
1.2	Requirements.....	1
<b>2</b>	<b>REFERENCES</b> .....	<b>2</b>
2.1	Normative References .....	2
2.2	Informative References .....	3
2.3	Reference Acquisition .....	3
<b>3</b>	<b>TERMS AND DEFINITIONS</b> .....	<b>4</b>
<b>4</b>	<b>ABBREVIATIONS AND ACRONYMS</b> .....	<b>5</b>
<b>5</b>	<b>OVERVIEW</b> .....	<b>6</b>
5.1	Residential SIP Telephony .....	6
5.2	Provisioning, Activation, Configuration and Management (PACM) .....	6
<b>6</b>	<b>PACKETCABLE RST - PACM ARCHITECTURE AND REQUIREMENTS</b> .....	<b>7</b>
6.1	PacketCable RST-PACM Functional Architecture .....	7
6.2	PacketCable RST-PACM Configuration.....	7
6.2.1	<i>XCAP Usage for the PacketCable "RST" Application Profile</i> .....	7
6.3	PacketCable RST-PACM Management .....	9
6.4	PacketCable RST-PACM component requirements.....	9
6.4.1	<i>UE requirements</i> .....	9
6.4.2	<i>E-DVA requirements</i> .....	10
6.4.3	<i>DHCP Server requirements</i> .....	14
6.4.4	<i>DNS Server requirements</i> .....	14
6.4.5	<i>PDS requirements</i> .....	14
6.4.6	<i>XDS requirements</i> .....	14
6.4.7	<i>Time Server requirements</i> .....	14
6.4.8	<i>EMS and NMS requirements</i> .....	14
6.4.9	<i>AS requirements</i> .....	14
<b>7</b>	<b>SAMPLE RST-PACM FLOWS AND EXAMPLES</b> .....	<b>15</b>
7.1	SIPPING-CONFIG Profiles and XCAP AUIDs .....	15
7.2	UE Profile retrieval.....	15
7.3	User Profile retrieval .....	16
7.4	RST Feature Profile retrieval.....	17
<b>ANNEX A</b>	<b>RST-PACM DATA MODEL</b> .....	<b>18</b>
A.1	RST Feature Profile .....	18
A.2	RST E-DVA Profile .....	50
<b>APPENDIX I</b>	<b>RST-PACM SMI DEFINITIONS</b> .....	<b>69</b>
I.1	SMI representation of the RST Feature Profile .....	69
I.2	SMI representation of the RST E-DVA Profile.....	93
<b>APPENDIX II</b>	<b>ACKNOWLEDGEMENTS</b> .....	<b>106</b>

## Figures

Figure 1 - PacketCable PACM Functional Architecture .....	7
Figure 2 - Obtaining the UE Profile .....	15
Figure 3 - Obtaining the User Profile .....	16
Figure 4 - Obtaining the RST Profile .....	17

## Tables

Table 1 - RFC 2863 ifTable, MIB-Object Details for E-DVA.....	12
Table 2 - RFC 4293 ipNetToPhysical MIB Object details for E-DVA Device Interfaces.....	13

# 1 SCOPE

## 1.1 Introduction and Purpose

The PacketCable Residential SIP Telephony (RST) Feature specifies an implementation of common residential telephony features in a PacketCable network with PacketCable User Equipment (UE). To support the RST features being defined (e.g., caller ID, call forwarding, three-way calling etc), the UEs need to support Provisioning, Activation, Configuration and Management (PACM) in a PacketCable network.

The PacketCable architecture does provide a generic PACM architecture, but requires service specific efforts like RST to define service data models and borrow requirements based on the IP Network Environments, UE types and service requirements. This document specifies the PACM requirements and the RST data model, as applicable to UEs providing PacketCable RST Features.

## 1.2 Requirements

Throughout this document, the words that are used to define the significance of particular requirements are capitalized. These words are:

"MUST"	This word means that the item is an absolute requirement of this specification.
"MUST NOT"	This phrase means that the item is an absolute prohibition of this specification.
"SHOULD"	This word means that there may exist valid reasons in particular circumstances to ignore this item, but the full implications should be understood and the case carefully weighed before choosing a different course.
"SHOULD NOT"	This phrase means that there may exist valid reasons in particular circumstances when the listed behavior is acceptable or even useful, but the full implications should be understood and the case carefully weighed before implementing any behavior described with this label.
"MAY"	This word means that this item is truly optional. One vendor may choose to include the item because a particular marketplace requires it or because it enhances the product, for example; another vendor may omit the same item.

## 2 REFERENCES

### 2.1 Normative References

In order to claim compliance with this specification, it is necessary to conform to the following standards and other works as indicated, in addition to the other requirements of this specification. Notwithstanding, intellectual property rights may be required to use or implement such normative references.

- [E-DVA] PacketCable Residential SIP Telephony E-DVA Specification, PKT-SP-RST-E-DVA-I01-060927, September 27, 2006, Cable Television Laboratories, Inc.
- [ID SIPCFG] IETF Internet-Draft, A Framework for Session Initiation Protocol User Agent Profile Delivery, draft-ietf-sipping-config-framework-08, March 2006, work in progress.
- [ID XCAP] IETF Internet-Draft, The Extensible Markup Language (XML) Configuration Access Protocol (XCAP), draft-ietf-simple-xcap-11, May 2006, work in progress.
- [MEM1.5] PacketCable 1.5 Management Event Mechanism Specification, PKT-SP-MEM1.5-I02-050812, August 12, 2005, Cable Television Laboratories, Inc.
- [MIB-BB] CableLabs Battery Backup MIB Specification, CL-SP-MIB-BB-I01-050128, January 28, 2005, Cable Television Laboratories, Inc.
- [OSSIV2.0] DOCSIS 2.0 Operations Support System Interface Specification, CM-SP-OSSIV2.0-I09-050812, August 12, 2005, Cable Television Laboratories, Inc.
- [PACM] PacketCable Provisioning, Activation, Configuration, and Management Specification, PKT-SP-PACM-I01-060406, April 6, 2006, Cable Television Laboratories, Inc.
- [PKT 33.210] PacketCable Network Domain Security Specification 3GPP TS 33.210, PKT-SP-33.210-I01-060406, April 6, 2006, Cable Television Laboratories, Inc.
- [PKT 24.229] PacketCable SIP and SDP Stage 3 Specification 3GPP TS 24.229, PKT-SP-24.229-I01-060406, April 6, 2006, Cable Television Laboratories, Inc.
- [RFC 2011] IETF RFC 2011, SNMPv2 Management Information Base for the Internet Protocol using SMIV2, November 1996.
- [RFC 2013] IETF RFC 2013, SNMPv2 Management Information Base for the User Datagram Protocol using SMIV2, November 1996.
- [RFC 2863] IETF RFC 2863, The Interfaces Group MIB, June 2000.
- [RFC 4293] IETF RFC 4293, Management Information Base for the Internet Protocol (IP), April 2006.
- [RSTF] Residential SIP Telephony Feature Specification, PKT-SP-RSTF-I01-060927, September 27, 2006, Cable Television Laboratories, Inc.

## 2.2 Informative References

This specification uses the following informative references.

[ARCH-            PacketCable Architecture Framework Technical Report, PKT-TR-ARCH-FRM-V01-  
FRM TR]            060406, April 6, 2006, Cable Television Laboratories, Inc.

## 2.3 Reference Acquisition

- Cable Television Laboratories, Inc., 858 Coal Creek Circle, Louisville, CO 80027;  
Phone 303-661-9100; Fax 303-661-9199; Internet: <http://www.cablelabs.com/>
- Internet Engineering Task Force (IETF), Internet: <http://www.ietf.org/>  
Note: Internet-Drafts are draft documents valid for a maximum of six months and may be updated,  
replaced, or obsoleted by other documents at any time.  
The list of current Internet-Drafts can be accessed at <http://www.ietf.org/ietf/1id-abstracts.txt>.

### 3 TERMS AND DEFINITIONS

This specification uses the following terms:

<b>3rd Generation Partnership Project</b>	The 3rd Generation Partnership Project (3GPP) is a collaboration agreement that was established in December 1998. The collaboration agreement brings together a number of telecommunications standards bodies which are known as "Organizational Partners" that includes ARIB, CCSA, ETSI, ATIS, TTA, and TTC.
<b>Activation</b>	Activation is the process of controlling the state of entities, features or services.
<b>Application Unique Identifier</b>	A unique identifier within the namespace of application unique IDs (AUID) created by the XCAP specification [ID XCAP]. The AUID differentiates XCAP resources accessed by one application from XCAP resources accessed by another.
<b>Configuration</b>	Configuration is the process of defining and propagating data to network elements for providing services.
<b>Data Model</b>	An abstract model that describes representation of data in a system.
<b>Management</b>	Management refers to the protocols, methodologies and interfaces that enable oversight services in a Service Provider Network.
<b>Provisioning</b>	Provisioning refers to the processes involved in the initialization of user attributes and resources to provide services to a User. This involves protocols, methodologies, and interfaces to network elements such as: Order Entry and Workflow Systems that carry out business processes, Operational Support Elements that handle network resources, Application Servers that offer services and Use Equipment that offer services.

## 4 ABBREVIATIONS AND ACRONYMS

This specification uses the following abbreviations:

<b>3GPP</b>	3rd Generation Partnership Project
<b>ACL</b>	Access Control List
<b>AUID</b>	Application Unique Identifier
<b>DHCP</b>	Dynamic Host Configuration Protocol
<b>DNS</b>	Domain Name System
<b>EMS</b>	Element Management System
<b>MIB</b>	Management Information Base
<b>PACM</b>	Provisioning, Activation, Configuration, and Management
<b>P-CSCF</b>	Proxy Call Session and Control Function
<b>PDS</b>	Profile Delivery Server
<b>RST</b>	Residential SIP Telephony
<b>SIP</b>	Session Initiation Protocol
<b>SMI</b>	Structure (and Identification) of Management Information
<b>SNMP</b>	Simple Network Management Protocol
<b>UE</b>	User Equipment
<b>URI</b>	Uniform Resource Indicator
<b>XCAP</b>	Extensible Markup Language (XML) Configuration Access Protocol
<b>XDS</b>	XCAP Document Server
<b>XSD</b>	XML Schema Definition

## 5 OVERVIEW

PacketCable is a CableLabs specification effort designed to support the convergence of voice, video, data, and mobility technologies. The PacketCable architecture describes a set of functional groups and logical entities, as well as a set of interfaces that support the information flows exchanged between entities. For more information about PacketCable, please refer to the PacketCable Architecture Framework Technical Report [ARCH-FRM TR].

As part of these efforts, PacketCable specifies services such as Residential SIP Telephony (RST), built upon the PacketCable architecture. Support of RST in a PacketCable network also requires specification of applicable architectural requirements related to UEs, PACM, Accounting, etc. This is one such document, and specifies requirements related to PACM, as applicable to the UEs supporting RST. Further, within the context of this document any reference to a UE needs to be interpreted as a UE that supports RST features, sometimes referred to as a RST UE.

### 5.1 Residential SIP Telephony

The PacketCable RST Feature specification documents an implementation of common residential telephony features in a PacketCable network, including, but not limited to: caller ID, call forwarding, hold, transfer, three-way calling, emergency calling, and operator service. For more information, please refer to [RSTF].

### 5.2 Provisioning, Activation, Configuration and Management (PACM)

The PacketCable PACM specification documents reference points, protocols and data models to support Provisioning, Activation, Configuration and Management requirements in a PacketCable network. Further, the specification requires PacketCable feature specifications, such as RST to utilize and mandate reference points; and extend the data models as required to support the defined features. For more information, please refer to [PACM].

## 6 PACKETCABLE RST - PACM ARCHITECTURE AND REQUIREMENTS

### 6.1 PacketCable RST-PACM Functional Architecture

The PacketCable RST-PACM functional architecture is depicted in Figure 1.

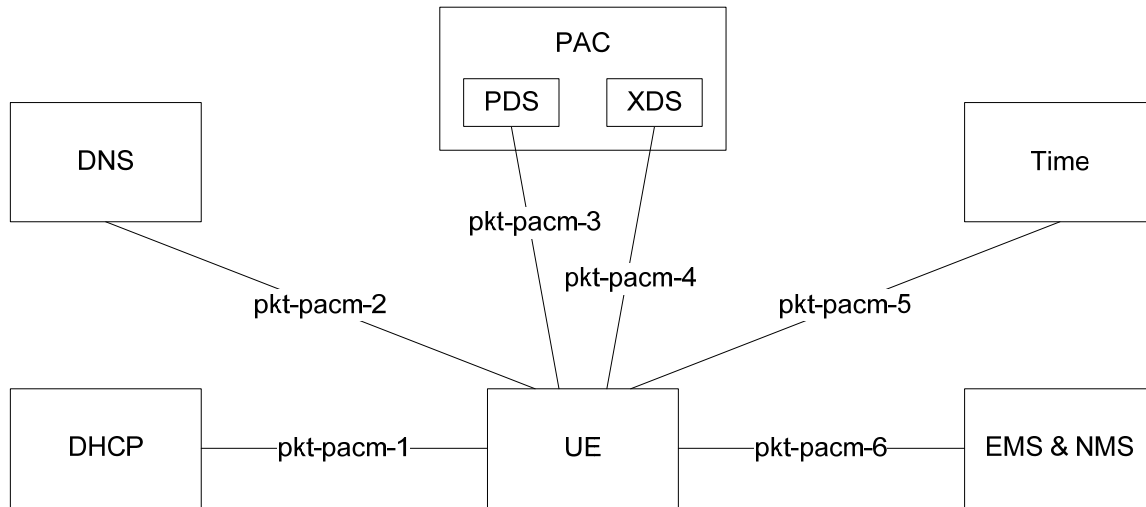

*Figure 1 - PacketCable PACM Functional Architecture*

### 6.2 PacketCable RST-PACM Configuration

The RST-PACM configuration derives from the configuration requirements as defined in [PACM]. This includes the management data model and the reference points: pkt-pacm-3 and pkt-pacm-4. Based on the configuration data model defined in [PACM], Annex A.1 of this specification contains the RST configuration data model, represented as an XML Schema.

#### 6.2.1 XCAP Usage for the PacketCable "RST" Application Profile

The PacketCable RST Feature profile described by the XML Schema in Annex A.1 of this specification corresponds to an "application" profile, as defined in [ID SIPCFG]. Its XCAP usage is specified in the following sections.

##### 6.2.1.1 AUID

An XDS supporting PacketCable RST features **MUST** set the Application Unique ID (AUID) for the PacketCable RST Feature profile to be "com.cablelabs.pkt.rst".

##### 6.2.1.2 Default Namespace Binding

The default namespace binding for the PacketCable RST Feature profile is:

<http://www.cablelabs.com/namespaces/PacketCable/R2/XSD/smi/CL-PKTC-RST>

### 6.2.1.3 XML Data Validation

The mime-type for the PacketCable RST Feature profile is "application/xml".

Uniqueness of index attributes in the PacketCable RST Feature profile document **MUST** be enforced, as specified using the <unique> element in the schema definition, by the XDS. If the <unique> element is not used in the schema definition, then attributes whose <annotation> indicates they are index attributes is required to be unique within the scope of similar elements under the same containing element and **MUST** be adhered to by the UE and enforced by the XDS.

The PacketCable RST Service Profile document may reference an external document when the <PktcPACMXData> element is used (see [PACM]). This reference may be a relative URL, which is relative to the XCAP Root, an absolute URL, or a reference to an additional profile subscription defined by an AUID and optional document URL. When the UE is granted write access to this type of reference, it is the responsibility of the UE to ensure referential integrity. Trusted network elements that are allowed to change this type of reference and alter the referenced document are similarly responsible for referential integrity between the referenced document and the User document. The XCAP server (XDS entity) does not provide any integrity enforcement for these references.

The PacketCable RST Feature profile document may reference an external access control document (see [PACM]). This is a relative URL reference, which is relative to the XCAP Root. The UE **MUST NOT** write, nor be authorized to write, this Access Control List (ACL) reference within the RST profile document. Further, the XDS **MUST NOT** authorize the UE to create, modify or delete the ACL document. Trusted network elements that are allowed to change this reference and alter the referenced ACL document **MUST** maintain referential integrity between the ACL document and the RST Feature profile document, both of which may reference each other. See the ACL document definition in [PACM] for more details. Because the XDS is required to enforce access control based on the referenced ACL document, the XDS **SHOULD** ensure referential integrity.

The PacketCable RST Feature profile document can also embed aggregated access control information, as specified by [PACM]. Whether embedded or external, the ACL document contains XPath information relating to the RST Feature profile document structure. There is no requirement that the XPath information correspond to existing RST profile document elements. This allows for ACL control of non-existent elements. However, XPath information in the ACL document **SHOULD** correspond to valid RST document structures.

### 6.2.1.4 Data Semantics

The data semantics for the PacketCable RST Feature profile document are specified in the <annotation> elements of the PacketCable RST XSD.

### 6.2.1.5 Naming Conventions

By default, the XDS **SHOULD** reference the PacketCable RST Feature Profile document as "RST-Profile", and ensure it appears under the user-specific portion of the XCAP URL path for the PacketCable RST features AUID, as specified in Section 6.2.1.1.

### 6.2.1.6 Resource Interdependencies

The PacketCable RST Feature profile document may be dependent on an external ACL document, as described in [PACM]. The PacketCable RST document can also be dependent on other external documents and resources, referenced in <PktcPACMXData> elements in the document. See the XML Data Validation Section 6.2.1.3 for more details.

### **6.2.1.7 Authorization Policies**

Each UE, acting on behalf of a Public Identity for which it has credentials and which is authorized for this AUID, is able to access (read, modify, and delete) the profile document(s) below the user directory for that Public Identity on the XDS implementing this AUID. The XCAP User Identifier (XUI) portion of the document path corresponds to the particular Public Identity. Further, all UEs authorized to access this AUID are able to read documents within the "global" directory of this AUID.

The default authorization policy defined in [ID XCAP], section 5.7, **MUST** be supported by all PacketCable elements.

Authorization for modification of specific portions of the PacketCable RST document content **MUST** be enforced by the XDS, according to the ACL rules associated with that element as specified in [PACM]. The <PKTC-ACL: aggregated-acls> element of the RST document, if present, **SHOULD** contain explicit inline access control preventing UE write access. The XDS **MAY** deny write access by the UE to the <PKTC-ACL: aggregated-acls> element despite the absence of explicit inline access control. Trusted network elements, explicitly defined the XDS, can freely modify all documents, including global documents, and correspond to "Network" entities with respect to specific ACL rules.

## **6.3 PacketCable RST-PACM Management**

The RST-PACM management derives from the management requirements as defined in [PACM]. This includes the management data model and the reference point pkt-pacm-6. Based on the configuration data model defined in [PACM], Annex A.1 of this specification contains the RST configuration data model, represented as an XML Schema.

## **6.4 PacketCable RST-PACM component requirements**

### **6.4.1 UE requirements**

UEs **MUST** support the following:

- UE requirements specified in [PACM], unless superseded by requirements in this specification
- configuration data model specified in Annex A.1
- provisioning flow requirements specified in the contained sub-sections, in the order of appearance

It is to be noted that this version of the specification supports UEs that can operate in both controlled and uncontrolled environments. UE specifications may qualify or choose an environment, if required.

#### **6.4.1.1 Network participation**

If a UE has control over IP connectivity, it **MUST** perform Network Participation as defined in [PACM].

#### **6.4.1.2 P-CSCF Discovery**

A UE **MUST** perform P-CSCF discovery as defined in [PACM].

#### **6.4.1.3 UE registration and configuration retrieval**

A UE that only has certificate based credentials **MUST** follow the certificate bootstrapping procedures defined in [PACM].

A UE that possesses UE (device) credentials required for registration MUST register as defined in [PKT 24.229] before attempting to obtain configuration.

Once the UE has registered, it MUST attempt to obtain the UE configuration as specified in [PACM].

#### **6.4.1.4 User registration and configuration retrieval**

For each active User not prohibited by the UE configuration data, the UE MUST attempt User registration as specified in [PKT 24.229].

For each registered User connecting via the UE, the UE MUST obtain the User Configuration as specified in [PACM].

An active User, in the context of this specification, is defined as a User who is considered to obtain services perpetually, unless configured otherwise (e.g., an embedded device pre-configured with Users) or a User who explicitly requests service (e.g., User at a Kiosk).

#### **6.4.1.5 RST configuration retrieval**

For each User obtaining RST Feature, the PAC Element MUST include the RST Feature information in the User profile.

Further, the PAC Element MUST ensure the following:

- If the RST Feature information is embedded in the User Profile, it conforms to the XML Schema specified in Annex A.1.
- If the RST Feature information is referenced as an external profile, it uses the AUID defined in Section 6.2.1 and the profile MUST conform to the XML Schema specified in Annex A.1.

Upon retrieving the User Profile containing RST Feature information, if the configuration is not embedded, the UE MUST retrieve the RST Feature Profile using the mechanisms specified in [PACM].

#### **6.4.1.6 PACM Management MIB requirements**

[PACM] requires that the PacketCable feature specifications define the service interruption rules. In this regard, a UE supporting RST features MUST support the values of 'significant(1)' and 'none(2)' for the MIB Object titled 'pktcPACMMgtSvcIntImpact' and not indicate 'unsupported(3)' in relation to RST features. Further, the presence of a SIP session due to RST features (originating or terminating requests) MUST result in the UE reporting a value of 'significant(1)' for the particular User. All other scenarios, including but not limited to registrations and subscriptions MUST result in the UE reporting a value of 'none(2)'.

### **6.4.2 E-DVA requirements**

Embedded Digital Voice Adapters (E-DVA) are UEs that conform to the requirements specified in [E-DVA]. E-DVAs MUST conform to the UE requirements specified in Section 6.4.1. Further PACM requirements on E-DVAs are defined in the sub-sections that follow.

#### **6.4.2.1 Certificate Bootstrapping**

E-DVAs MUST support Certificate Bootstrapping as defined in [PACM]. In addition, as required in [PACM], this document specifies the certificate profile requirements as follows:

- The UE MUST follow the certificate profile described in [E-DVA].

- The PAC Element MUST follow the certificate profile described in [PKT 33.210].

#### **6.4.2.2 MIB requirements**

MIB requirements for E-DVAs are specified in this section.

##### **6.4.2.2.1 IF-MIB and MIB-II**

The Interfaces Group MIB (IF-MIB) is defined in [RFC 2863]. The IF-MIB is required for the definition of multiple interfaces in the E-DVA. The second version of the Management Information Base (MIB-II) is defined by [RFC 2011], [RFC 2013], and [RFC 4293] for use with network management protocols.

The E-DVA MUST implement the system, interfaces, Internet Protocol (IP) and transmission MIB objects.

Additionally, the E-DVA's MIB-II sysDescr and sysObjectID object MUST conform to the formats specified in [OSSIV2.0].

##### **6.4.2.2.2 "ifTable" Requirements**

An E-DVA's ifTable MUST contain information about all the endpoints. IfIndex MUST start with value of 9, be incremented sequentially and match the physical numbering of the telephony endpoints (indices 2 through 8 are reserved for future use and the usage of index 1 is defined later in this section). Each instance of the endpoint in an E-DVA MUST have a corresponding entry ("conceptual row") in the "ifTable" MIB Table.

For each "conceptual row" in the "ifTable" table that corresponds to a telephony endpoint, the following conceptual columns MUST be used:

- "ifIndex"
- "ifDescr"
- "ifType"
- "ifAdminStatus"
- "ifOperStatus"

Each conceptual row in "ifTable" that corresponds to a telephony endpoint MUST conform to the "IANAifType-MIB" definition for the PacketCable interface type:

- "ifType" – voiceOverCable (198)
- "ifDescr" – "Voice Over Cable Interface"

IfIndex 1 is used to recognize the DOCSIS Cable Modem behind which an eDVA is connected and the MIB modules involved are indicated in Table 1 and Table 2. E-DVA's MUST conform to the ifTable and ipNetToPhysical defined in Table 1 and Table 2.

**Table 1 - RFC 2863 ifTable, MIB-Object Details for E-DVA**

<b>RFC-2863 MIB-Object Details for E-DVA Device Interface</b>	<b>eDVA</b>
IfIndex	1
ifDescr: MUST match the text provided in the next column.	"DOCSIS Embedded Interface"
IfType	other(1)
IfMtu	0
IfSpeed	0
ifPhysAddress	eDVA MAC address
IfAdminStatus: Only up control is required for this interface, down(2) and testing(3) is out of the scope of this specification.	up(1)
ifOperStatus: only up report is required for this object, other options are out of the scope of this specification.	up(1)
IfLastChange	per RFC 2863
ifInOctets: This object is optional, if not implemented, it MUST return 0	(n), 0
IfInNUCastPkts	Deprecated
IfInDiscards	0
IfInErrors	0
IfUnknownProtos	0
ifOutOctets: This object is optional, if not implement MUST return 0	(n), 0
ifOutUCastPkts: This object is optional, if not implemented, it MUST return 0	(n), 0
IfOutNUCastPkts	Deprecated
IfOutDiscards	0
IfOutErrors	0
IfOutQlen	Deprecated
IfSpecific	Deprecated
ifXTable: entries in ifXtable for this type of interface are not required	NA

**Table 2 - RFC 4293 ipNetToPhysical MIB Object details for E-DVA Device Interfaces**

MIB- Object Name	eCM
ipNetToPhysicalIfIndex	1
ipNetToPhysicalPhysAddress	CM MAC Address
ipNetToPhysicalNetAddressType	ipv4(1), ipv6(2)
ipNetToPhysicalNetAddress	Acquired CM IP Address
ipNetToPhysicalLastUpdated	[RFC 4293]
ipNetToPhysicalType	static(4)
ipNetToPhysicalState	[RFC 4293]
ipNetToPhysicalRowStatus	'active'

**6.4.2.2.3 Battery Backup MIB Requirements**

E-DVAs supporting Battery Backup as indicated in [E-DVA] MUST support the Battery Backup MIB as indicated in [MIB-BB]. Additionally, E-DVAs MUST use the identifier "EDVA" (e.g. usage of the MIB Object upsIdentAttachedDevices).

**6.4.2.3 Reporting requirements**

E-DVAs MUST support the "Powering Events" defined in [MEM1.5] using the reporting mechanism defined in [PACM].

**6.4.2.4 Mapping of Users to Endpoints**

[PACM], as part of the configuration data model allows for configuration of Users on UEs (reference the data elements related to 'pkcPACMUEUsrTableEntry'). This section provides additional information on the mapping of Users to specific endpoints on the E-DVA. The mapping is accomplished by the following <keyword>:<value> definitions that can be used as part of the data element titled 'pkcPACMUEUsrAdditionalInfo', associated with each corresponding User indicated by the data element 'pkcPACMUEUsrId':

- APPLICABLE\_TO\_EPS:<Comma separated list of endpoints>
- DEFAULT\_FOR\_EPS:<Comma separated list of endpoints>

The UE Configuration MUST provide the mapping of Users to UEs and the mapping of Users to endpoints for all endpoints that have RST features enabled. The UE configuration, when indicating endpoints, MUST refer to them using the ifIndex values as defined in section 6.4.2.2.2.

The E-DVA MUST follow the mapping of Users to the UE and the Users to the endpoint as provided by the UE configuration. Additionally, the following rules apply:

- If an available endpoint on an E-DVA is not mapped to any User, the UE MUST NOT enable RST features on that endpoint.
- If a User is indicated as the default for the endpoint, the E-DVA MUST assume that the User is applicable to the endpoint, irrespective of the <APPLICABLE\_TO\_EPS> indicator.
- If there is only one User mapped to an endpoint, and in the absence of <DEFAULT\_FOR\_EPS> indicator, the E-DVA MUST assume the applicable User to be the default.

- If there are multiple default Users indicated for an endpoint, then the E-DVA MUST consider the first occurrence as the default User and report the additional default Users as part of the warnings pertaining to the UE configuration.

#### **6.4.3 DHCP Server requirements**

A DHCP Server supporting the PacketCable RST Feature MUST support the DHCP Server requirements specified in [PACM].

#### **6.4.4 DNS Server requirements**

A DNS Server supporting the PacketCable RST Feature MUST support the DNS Server requirements specified in [PACM].

#### **6.4.5 PDS requirements**

A PDS supporting the PacketCable RST Feature MUST support the following:

- PDS requirements specified in [PACM].
- UE and User AUIDs defined in [PACM].
- RST AUID defined in Section 6.2.1 of this specification.

#### **6.4.6 XDS requirements**

An XDS supporting the PacketCable RST Feature MUST support the following:

- XDS requirements specified in [PACM].
- Application usage for each AUID supported by the PDS.

#### **6.4.7 Time Server requirements**

A Time Server supporting the PacketCable RST Feature MUST support the Time Server requirements specified in [PACM].

#### **6.4.8 EMS and NMS requirements**

An EMS or NMS supporting the PacketCable RST Feature MUST support the EMS and NMS requirements specified in [PACM].

#### **6.4.9 AS requirements**

An AS supporting the PacketCable RST Feature and containing - or acting as - a PDS MUST support the PDS requirements specified in [PACM].

An AS supporting the PacketCable RST Feature and containing - or acting as - an XDS MUST support the XDS requirements specified in [PACM].

## 7 SAMPLE RST-PACM FLOWS AND EXAMPLES

This section provides a non-normative snapshot of a potential provisioning flow, based on the requirements specified in Section 6, as they relate to PacketCable RST configuration retrieval. This involves retrieval of the UE Profile, the User Profile, and the RST Feature data. Further, as indicated in Section 6.4.1.5, the User Profile may contain the RST feature data within or reference it via an external RST profile. The sample flow in this section assumes the latter. Further, retrieval of the RST EDVA profile is accomplished as part of the UE profile delivery and is not explicitly illustrated in the sample.

Additionally, the sections that follow assume completion of IP network participation, P-CSCF Discovery and registration.

### 7.1 SIPPING-CONFIG Profiles and XCAP AUIDs

The SIPPING-CONFIG profiles, corresponding data and the XCAP AUIDs used to support the RST Feature can be summarized as follows:

- The "device" profile corresponds to the UE data; the AUID for this is com.cablelabs.pkt.ue.
- The User "application" profile corresponds to the User data; the AUID for this is com.cablelabs.pkt.user.

If referenced as an external profile, the RST "application" profile corresponds to the RST feature data; the AUID for this is com.cablelabs.pkt.user.rst.

### 7.2 UE Profile retrieval

A PacketCable UE supporting RST initiates the configuration process by obtaining the UE profile. Figure 2 indicates a snapshot of the provisioning flow depicting retrieval of the UE profile.

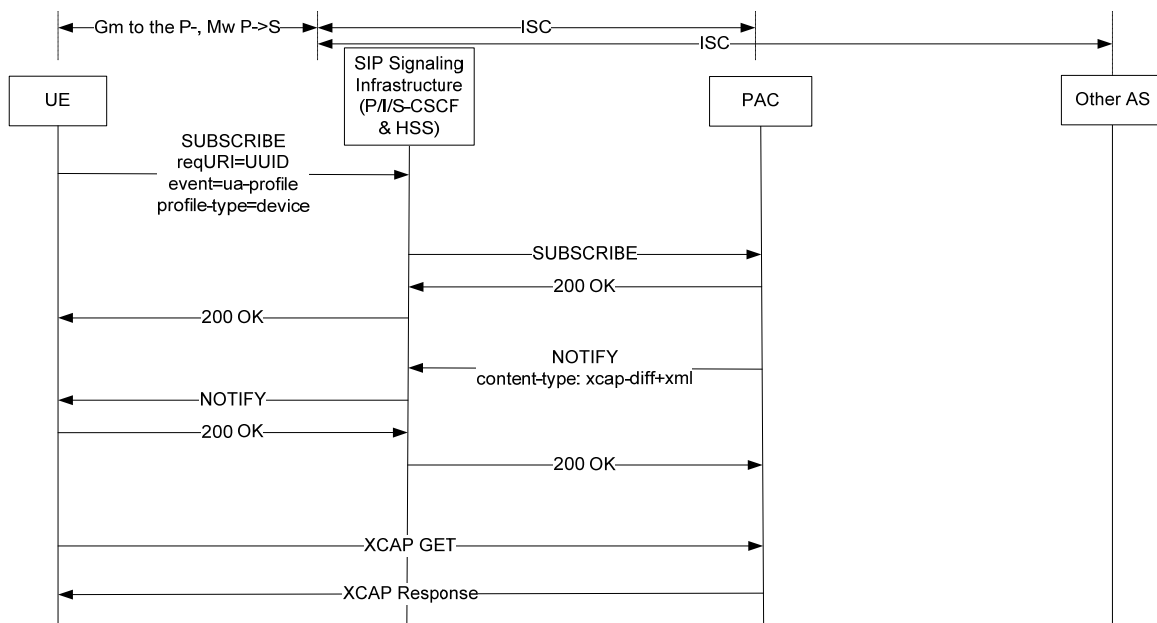

Figure 2 - Obtaining the UE Profile

The UE SUBSCRIBEs to the "device" profile using the Universally Unique Identifier (UUID) as the Request URI and the Service Provider domain name as the host portion (e.g., sip:urn%3auuid%3a<sample uuid>@<sample domain>). The Event header indicates that this is a "device" profile type as specified by [ID SIPCFG]; note that unlike the other Event header codings, this does not contain an AUID. An example of such an event header is:

Event: ua-profile;profile-type=device

Further the UE requests XCAP-diff format in all PacketCable profile subscriptions, by specifying "application/xcap-diff+xml" in the Accept header of the SUBSCRIBE message. This will ensure XCAP-diff content in the resultant NOTIFY.

Assuming a successful subscription a NOTIFY will be transmitted by the PAC server with XCAP-diff content. This will be used by the UE to construct an XCAP request for the device profile.

### 7.3 User Profile retrieval

Once the UE obtains the UE Profile, it proceeds to obtain User Profiles for each User configured, and not prohibited (via UE configuration) from network access. Figure 3 indicates a snapshot of the provisioning flow depicting retrieval of a User profile.

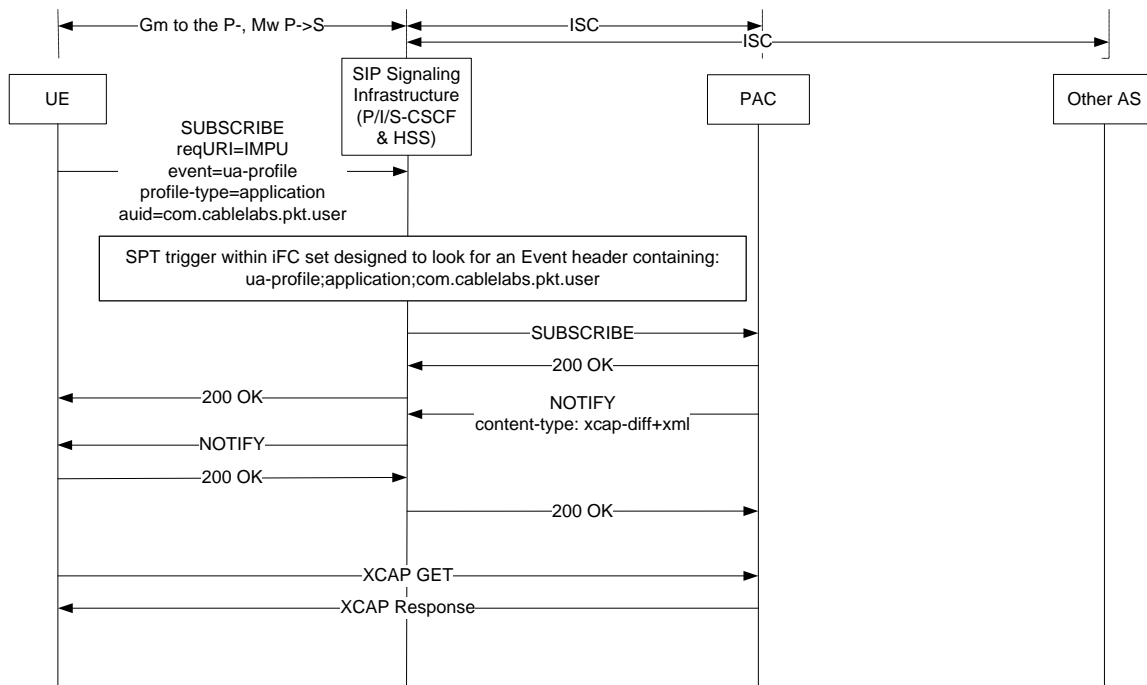

Figure 3 - Obtaining the User Profile

The UE SUBSCRIBEs to the "application" profile using its IM Public Identity (IMPU) as the Request URI, and the service provider domain as the host portion (e.g., sip:+13036619100@serviceprovider.com). The Event header indicates that this is an "application" profile type as specified in [ID SIPCFG], along with a PacketCable defined AUID indicating it to be a User Profile. An example of such an event header is:

Event: ua-profile;profile-type=application;auid=com.cablelabs.pkt.user

Assuming a successful subscription a NOTIFY will be returned by the PAC server. This will be used by the UE to construct an XCAP request to obtain the User Profile. This will contain the user profile data as identified in [PACM] section A.3. The User Profile obtained for a User subscribed to the PacketCable RST features may contain RST features within, or reference an external RST Feature profile reference. If it is an external RST feature profile, then the UE proceeds to obtain it as indicated in Section 7.4.

## 7.4 RST Feature Profile retrieval

Figure 4 indicates a snapshot of the provisioning flow depicting retrieval of the RST Feature profile.

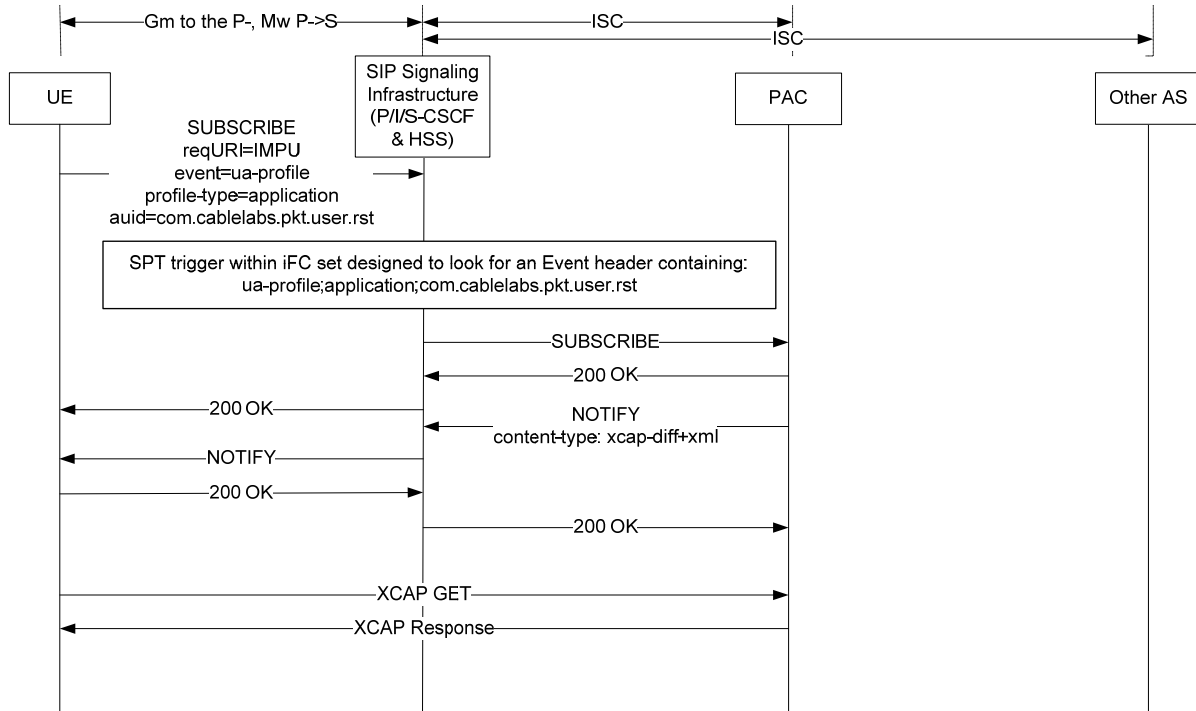

**Figure 4 - Obtaining the RST Profile**

If the User Profile indicated an external RST Feature Profile reference, the UE SUBSCRIBES to the "application" profile using its IMPU as the Request URI and the service provider domain as the host portion (i.e., sip:+19727617000@serviceprovider.com). The Event header indicates that this is an "application" profile type as specified in [ID SIPCFG], it also has an AUID emphasizing that this specifically is the PacketCable RSTfeature data. An example of such an event header is:

Event: ua-profile;profile-type=application;auid=com.cablelabs.pkt.user.rst

Assuming a successful subscription,a NOTIFY will be returned by the PAC Element. This will be used by the UE to construct an XCAP request to retrieve the User Profile.

## Annex A RST-PACM Data Model

### A.1 RST Feature Profile

The following is the XML Schema representing the RST Feature Profile. For the SMI version refer to Appendix I.1.

```
<?xml version="1.0"?>
<!-- 2006 (c)CableLabs. All rights reserved -->
<!--PacketCable R2 PACM: XML Schema Definitions for "CL-PKTC-RST" -->
<xsd:schema
xmlns="http://www.cablelabs.com/namespaces/PacketCable/R2/XSD/smi/v1/CL-PKTC-
RST" xmlns:xsd="http://www.w3.org/2001/XMLSchema"
xmlns:smi="http://www.cablelabs.com/namespaces/PacketCable/R2/XSD/smi/smi"
xmlns:SNMPv2-
SMI="http://www.cablelabs.com/namespaces/PacketCable/R2/XSD/smi/SNMPv2-SMI"
xmlns:SNMPv2-
CONF="http://www.cablelabs.com/namespaces/PacketCable/R2/XSD/smi/SNMPv2-CONF"
xmlns:SNMP-FRAMEWORK-
MIB="http://www.cablelabs.com/namespaces/PacketCable/R2/XSD/smi/SNMP-FRAMEWORK-
MIB" xmlns:SNMPv2-
TC="http://www.cablelabs.com/namespaces/PacketCable/R2/XSD/smi/SNMPv2-TC"
xmlns:CL-PKTC-TC="http://www.cablelabs.com/namespaces/PacketCable/R2/XSD/v1/CL-
PKTC-TC" xmlns:CLAB-DEF-
MIB="http://www.cablelabs.com/namespaces/PacketCable/R2/XSD/smi/CLAB-DEF-MIB"
xmlns:PKTC-ACLS="http://www.cablelabs.com/namespaces/PacketCable/R2/XSD/v1/CL-
PKTC-ACL" xmlns:CL-PKTC-BASE-
SVC="http://www.cablelabs.com/namespaces/PacketCable/R2/XSD/v1/CL-PKTC-BASE-SVC"
targetNamespace="http://www.cablelabs.com/namespaces/PacketCable/R2/XSD/smi/v1/C
L-PKTC-RST" elementFormDefault="qualified" attributeFormDefault="unqualified"
xml:lang="en">
  <xsd:annotation>
    <xsd:documentation>
      This XML Schema contains configuration data
      elements for the RST Features as required by
      the PacketCable Residential SIP Telephony (RST)
      Provisioning, Activation, Configuration and
      Management(PACM) specification.
    </xsd:documentation>
  </xsd:annotation>
  <xsd:import
namespace="http://www.cablelabs.com/namespaces/PacketCable/R2/XSD/smi/smi"
schemaLocation="http://www.cablelabs.com/namespaces/PacketCable/R2/XSD/smi/SMI.x
sd"/>
  <xsd:import
namespace="http://www.cablelabs.com/namespaces/PacketCable/R2/XSD/smi/SNMPv2-
SMI"
schemaLocation="http://www.cablelabs.com/namespaces/PacketCable/R2/XSD/smi/SNMPv
2-SMI.xsd"/>
  <xsd:import
namespace="http://www.cablelabs.com/namespaces/PacketCable/R2/XSD/smi/SNMPv2-
CONF"
schemaLocation="http://www.cablelabs.com/namespaces/PacketCable/R2/XSD/smi/SNMPv
2-CONF.xsd"/>
  <xsd:import
namespace="http://www.cablelabs.com/namespaces/PacketCable/R2/XSD/smi/SNMP-
FRAMEWORK-MIB"
schemaLocation="http://www.cablelabs.com/namespaces/PacketCable/R2/XSD/smi/SNMP-
FRAMEWORK-MIB.xsd"/>
  <xsd:import
namespace="http://www.cablelabs.com/namespaces/PacketCable/R2/XSD/smi/SNMPv2-TC"
schemaLocation="http://www.cablelabs.com/namespaces/PacketCable/R2/XSD/smi/SNMPv
2-TC.xsd"/>
```

```

    <xsd:import
    namespace="http://www.cablelabs.com/namespaces/PacketCable/R2/XSD/v1/CL-PKTC-TC"
    schemaLocation="http://www.cablelabs.com/namespaces/PacketCable/R2/XSD/v1/CL-
    PKTC-TC.xsd"/>
    <xsd:import
    namespace="http://www.cablelabs.com/namespaces/PacketCable/R2/XSD/smi/CLAB-DEF-
    MIB"
    schemaLocation="http://www.cablelabs.com/namespaces/PacketCable/R2/XSD/smi/CLAB-
    DEF-MIB.xsd"/>
    <xsd:import
    namespace="http://www.cablelabs.com/namespaces/PacketCable/R2/XSD/v1/CL-PKTC-
    ACL"
    schemaLocation="http://www.cablelabs.com/namespaces/PacketCable/R2/XSD/v1/CL-
    PKTC-ACL.xsd"/>
    <xsd:import
    namespace="http://www.cablelabs.com/namespaces/PacketCable/R2/XSD/v1/CL-PKTC-
    BASE-SVC"
    schemaLocation="http://www.cablelabs.com/namespaces/PacketCable/R2/XSD/v1/CL-
    PKTC-BASE-SVC.xsd"/>
    <xsd:element name="CL-PKTC-RST">
        <xsd:annotation>
            <xsd:appinfo>
                <PKTC-ACLS:access-control>NetworkWritable</PKTC-ACLS:access-control>
            </xsd:appinfo>
        </xsd:annotation>
        <xsd:complexType>
            <xsd:sequence>
                <xsd:element ref="PKTC-ACLS:aggregated-acls" minOccurs="0"/>
                <xsd:element name="pktcPACMRSTObjects" type="pktcPACMRSTObjectsType"
    minOccurs="0">
                    <xsd:annotation>
                        <xsd:appinfo>
                            <maxAccess>unknown</maxAccess>
                            <oid>1.3.6.1.4.1.4491.2.2.7.4.1</oid>
                            <status>unknown</status>
                        </xsd:appinfo>
                    </xsd:annotation>
                    </xsd:element>
                    <xsd:element name="pktcRSTBasicCallFeatProfile"
    type="pktcRSTBasicCallFeatProfileType" minOccurs="0">
                        <xsd:annotation>
                            <xsd:appinfo>
                                <maxAccess>unknown</maxAccess>
                                <oid>1.3.6.1.4.1.4491.2.2.7.4.1.3.1</oid>
                                <status>unknown</status>
                            </xsd:appinfo>
                        </xsd:annotation>
                        </xsd:element>
                        <xsd:element name="pktcRSTAncFeatProfile" type="pktcRSTAncFeatProfileType"
    minOccurs="0">
                            <xsd:annotation>
                                <xsd:appinfo>
                                    <maxAccess>unknown</maxAccess>
                                    <oid>1.3.6.1.4.1.4491.2.2.7.4.1.3.2</oid>
                                    <status>unknown</status>
                                </xsd:appinfo>
                            </xsd:annotation>
                            </xsd:element>
                            <xsd:element name="pktcRSTLocalMediaProfile"
    type="pktcRSTLocalMediaProfileType" minOccurs="0">
                                <xsd:annotation>
                                    <xsd:appinfo>
                                        <maxAccess>unknown</maxAccess>
                                        <oid>1.3.6.1.4.1.4491.2.2.7.4.1.3.3</oid>
                                        <status>unknown</status>
                                    </xsd:appinfo>
                                </xsd:annotation>
                            </xsd:element>
                        </xsd:element>
                    </xsd:sequence>
                </xsd:complexType>
            </xsd:element>
        </xsd:annotation>
    </pre>

```

```

    </xsd:element>
    <xsd:element name="pktcRSTAncLangProfile" type="pktcRSTAncLangProfileType"
minOccurs="0">
    <xsd:annotation>
    <xsd:appinfo>
    <maxAccess>unknown</maxAccess>
    <oid>1.3.6.1.4.1.4491.2.2.7.4.1.3.4</oid>
    <status>unknown</status>
    </xsd:appinfo>
    </xsd:annotation>
  </xsd:element>
  <xsd:element name="pktcRSTUEStatusChangeProfile"
type="pktcRSTUEStatusChangeProfileType" minOccurs="0">
  <xsd:annotation>
  <xsd:appinfo>
  <maxAccess>unknown</maxAccess>
  <oid>1.3.6.1.4.1.4491.2.2.7.4.1.3.5</oid>
  <status>unknown</status>
  </xsd:appinfo>
  </xsd:annotation>
</xsd:element>
<xsd:element name="pktcRSTNoAnsTimeoutProfile"
type="pktcRSTNoAnsTimeoutProfileType" minOccurs="0">
  <xsd:annotation>
  <xsd:appinfo>
  <maxAccess>unknown</maxAccess>
  <oid>1.3.6.1.4.1.4491.2.2.7.4.1.3.6</oid>
  <status>unknown</status>
  </xsd:appinfo>
  </xsd:annotation>
</xsd:element>
<xsd:element name="pktcRSTCallerIdProfile" type="pktcRSTCallerIdProfileType"
minOccurs="0">
  <xsd:annotation>
  <xsd:appinfo>
  <maxAccess>unknown</maxAccess>
  <oid>1.3.6.1.4.1.4491.2.2.7.4.1.3.7</oid>
  <status>unknown</status>
  </xsd:appinfo>
  </xsd:annotation>
</xsd:element>
<xsd:element name="pktcRSTCIDDisplayProfile"
type="pktcRSTCIDDisplayProfileType" minOccurs="0">
  <xsd:annotation>
  <xsd:appinfo>
  <maxAccess>unknown</maxAccess>
  <oid>1.3.6.1.4.1.4491.2.2.7.4.1.3.8</oid>
  <status>unknown</status>
  </xsd:appinfo>
  </xsd:annotation>
</xsd:element>
<xsd:element name="pktcRSTCIDCallBlkProfile"
type="pktcRSTCIDCallBlkProfileType" minOccurs="0">
  <xsd:annotation>
  <xsd:appinfo>
  <maxAccess>unknown</maxAccess>
  <oid>1.3.6.1.4.1.4491.2.2.7.4.1.3.9</oid>
  <status>unknown</status>
  </xsd:appinfo>
  </xsd:annotation>
</xsd:element>
<xsd:element name="pktcRSTCIDCallDelProfile"
type="pktcRSTCIDCallDelProfileType" minOccurs="0">
  <xsd:annotation>
  <xsd:appinfo>
  <maxAccess>unknown</maxAccess>
  <oid>1.3.6.1.4.1.4491.2.2.7.4.1.3.10</oid>

```

```

        <status>unknown</status>
    </xsd:appinfo>
</xsd:annotation>
</xsd:element>
<xsd:element name="pktrSTCFwdProfile" type="pktrSTCFwdProfileType"
minOccurs="0">
    <xsd:annotation>
    <xsd:appinfo>
        <maxAccess>unknown</maxAccess>
        <oid>1.3.6.1.4.1.4491.2.2.7.4.1.3.11</oid>
        <status>unknown</status>
    </xsd:appinfo>
    </xsd:annotation>
</xsd:element>
<xsd:element name="pktrSTCallWaitProfile" type="pktrSTCallWaitProfileType"
minOccurs="0">
    <xsd:annotation>
    <xsd:appinfo>
        <maxAccess>unknown</maxAccess>
        <oid>1.3.6.1.4.1.4491.2.2.7.4.1.3.12</oid>
        <status>unknown</status>
    </xsd:appinfo>
    </xsd:annotation>
</xsd:element>
<xsd:element name="pktrSTCallHoldProfile" type="pktrSTCallHoldProfileType"
minOccurs="0">
    <xsd:annotation>
    <xsd:appinfo>
        <maxAccess>unknown</maxAccess>
        <oid>1.3.6.1.4.1.4491.2.2.7.4.1.3.13</oid>
        <status>unknown</status>
    </xsd:appinfo>
    </xsd:annotation>
</xsd:element>
<xsd:element name="pktrSTCallTransProfile"
type="pktrSTCallTransProfileType" minOccurs="0">
    <xsd:annotation>
    <xsd:appinfo>
        <maxAccess>unknown</maxAccess>
        <oid>1.3.6.1.4.1.4491.2.2.7.4.1.3.14</oid>
        <status>unknown</status>
    </xsd:appinfo>
    </xsd:annotation>
</xsd:element>
<xsd:element name="pktrST3WCFeatureProfile"
type="pktrST3WCFeatureProfileType" minOccurs="0">
    <xsd:annotation>
    <xsd:appinfo>
        <maxAccess>unknown</maxAccess>
        <oid>1.3.6.1.4.1.4491.2.2.7.4.1.3.15</oid>
        <status>unknown</status>
    </xsd:appinfo>
    </xsd:annotation>
</xsd:element>
<xsd:element name="pktrSTDNDProfile" type="pktrSTDNDProfileType"
minOccurs="0">
    <xsd:annotation>
    <xsd:appinfo>
        <maxAccess>unknown</maxAccess>
        <oid>1.3.6.1.4.1.4491.2.2.7.4.1.3.16</oid>
        <status>unknown</status>
    </xsd:appinfo>
    </xsd:annotation>
</xsd:element>
<xsd:element name="pktrSTSubProgPINProfile"
type="pktrSTSubProgPINProfileType" minOccurs="0">
    <xsd:annotation>

```

```

    <xsd:appinfo>
      <maxAccess>unknown</maxAccess>
      <oid>1.3.6.1.4.1.4491.2.2.7.4.1.3.17</oid>
      <status>unknown</status>
    </xsd:appinfo>
  </xsd:annotation>
</xsd:element>
<xsd:element name="pktcRSTMWIPProfile" type="pktcRSTMWIPProfileType"
minOccurs="0">
  <xsd:annotation>
    <xsd:appinfo>
      <maxAccess>unknown</maxAccess>
      <oid>1.3.6.1.4.1.4491.2.2.7.4.1.3.18</oid>
      <status>unknown</status>
    </xsd:appinfo>
  </xsd:annotation>
</xsd:element>
<xsd:element name="pktcRSTAutoRecallProfile"
type="pktcRSTAutoRecallProfileType" minOccurs="0">
  <xsd:annotation>
    <xsd:appinfo>
      <maxAccess>unknown</maxAccess>
      <oid>1.3.6.1.4.1.4491.2.2.7.4.1.3.19</oid>
      <status>unknown</status>
    </xsd:appinfo>
  </xsd:annotation>
</xsd:element>
<xsd:element name="pktcRSTAutoCallbackProfile"
type="pktcRSTAutoCallbackProfileType" minOccurs="0">
  <xsd:annotation>
    <xsd:appinfo>
      <maxAccess>unknown</maxAccess>
      <oid>1.3.6.1.4.1.4491.2.2.7.4.1.3.20</oid>
      <status>unknown</status>
    </xsd:appinfo>
  </xsd:annotation>
</xsd:element>
<xsd:element name="pktcRSTBusyLineProfile" type="pktcRSTBusyLineProfileType"
minOccurs="0">
  <xsd:annotation>
    <xsd:appinfo>
      <maxAccess>unknown</maxAccess>
      <oid>1.3.6.1.4.1.4491.2.2.7.4.1.3.21</oid>
      <status>unknown</status>
    </xsd:appinfo>
  </xsd:annotation>
</xsd:element>
<xsd:element name="pktcRSTEmSvcProfile" type="pktcRSTEmSvcProfileType"
minOccurs="0">
  <xsd:annotation>
    <xsd:appinfo>
      <maxAccess>unknown</maxAccess>
      <oid>1.3.6.1.4.1.4491.2.2.7.4.1.3.22</oid>
      <status>unknown</status>
    </xsd:appinfo>
  </xsd:annotation>
</xsd:element>
<xsd:element name="pktcRSTAncMapEntry" type="pktcRSTAncMapEntryType"
minOccurs="0" maxOccurs="unbounded">
  <xsd:annotation>
    <xsd:appinfo>
      <maxAccess>not-accessible</maxAccess>
      <oid>1.3.6.1.4.1.4491.2.2.7.4.1.3.2.5.1</oid>
      <status>current</status>
      <PKTC-ACLS:access-control>NetworkWritable</PKTC-ACLS:access-control>
      <user-hint>read-only</user-hint>
    </xsd:appinfo>

```

```
<xsd:documentation>
    This data table represents the announcement MAP entries.
    Each entry in this table represents the Announcement MAP
    entry URI corresponding to a response code.
</xsd:documentation>
</xsd:annotation>
</xsd:element>
<xsd:element name="pktcRSTAncMediaMapEntry"
type="pktcRSTAncMediaMapEntryType" minOccurs="0" maxOccurs="unbounded">
<xsd:annotation>
<xsd:appinfo>
<maxAccess>not-accessible</maxAccess>
<oid>1.3.6.1.4.1.4491.2.2.7.4.1.3.2.6.1</oid>
<status>current</status>
<PKTC-ACLS:access-control>NetworkWritable</PKTC-ACLS:access-control>
<user-hint>read-only</user-hint>
</xsd:appinfo>
<xsd:documentation>
    This data table represents the announcement Media MAP
entries.
    Each entry in this table represents the Announcement Media
MAP
    entry URI corresponding to an announcement identifier.
</xsd:documentation>
</xsd:annotation>
</xsd:element>
<xsd:element name="pktcRSTLocalMediaEntry" type="pktcRSTLocalMediaEntryType"
minOccurs="0" maxOccurs="unbounded">
<xsd:annotation>
<xsd:appinfo>
<maxAccess>not-accessible</maxAccess>
<oid>1.3.6.1.4.1.4491.2.2.7.4.1.3.3.1.1</oid>
<status>current</status>
<PKTC-ACLS:access-control>NetworkWritable</PKTC-ACLS:access-control>
<user-hint>read-only</user-hint>
</xsd:appinfo>
<xsd:documentation>
    Each entry in this table represents the Local Media
entries.
</xsd:documentation>
</xsd:annotation>
</xsd:element>
</xsd:sequence>
</xsd:complexType>
</xsd:element>
<xsd:complexType name="pktcPACMRSTObjectsType">
<xsd:complexContent>
<xsd:extension base="CL-PKTC-BASE-SVC:pktcPACMSvcFeature">
<xsd:sequence>
<xsd:element name="pktcPACMRSTMinorVersion" type="smi:Integer32"
default="0">
<xsd:annotation>
<xsd:appinfo>
<maxAccess>read-only</maxAccess>
<oid>1.3.6.1.4.1.4491.2.2.7.4.1.1</oid>
<status>current</status>
<default>0</default>
<PKTC-ACLS:access-control>NetworkWritable</PKTC-ACLS:access-control>
<user-hint>R0</user-hint>
</xsd:appinfo>
<xsd:documentation>
    The default value of this MIB Object contains the minor version
of the data model.
</xsd:documentation>
</xsd:annotation>
</xsd:element>
```

```

    <xsd:element name="eXTObjpktcRSTObjects" type="CL-PKTC-
TC:PktcPACMExtension" minOccurs="0">
  <xsd:annotation>
    <xsd:appinfo>
      <maxAccess>read-only</maxAccess>
      <oid>1.3.6.1.4.1.4491.2.2.7.4.1.4</oid>
      <status>current</status>
      <PKTC-ACLS:access-control>NetworkWritable</PKTC-ACLS:access-control>
      <user-hint>RW</user-hint>
    </xsd:appinfo>
    <xsd:documentation>
      Extension object for 'pktcRSTObjects'.
    </xsd:documentation>
  </xsd:annotation>
</xsd:element>
  <xsd:any namespace="##other" processContents="lax" minOccurs="0"
maxOccurs="unbounded" />
</xsd:sequence>
</xsd:extension>
</xsd:complexContent>
</xsd:complexType>
<xsd:complexType name="pktcRSTBasicCallFeatProfileType">
  <xsd:complexContent>
    <xsd:extension base="CL-PKTC-BASE-SVC:pktcPACMSvcFeature">
      <xsd:sequence>
        <xsd:element name="pktcRSTBasicCallDigitMap" type="PktcRSTDIGITMAP">
          <xsd:annotation>
            <xsd:appinfo>
              <maxAccess>read-write</maxAccess>
              <oid>1.3.6.1.4.1.4491.2.2.7.4.1.3.1.1</oid>
              <status>current</status>
              <PKTC-ACLS:access-control>NetworkWritable</PKTC-ACLS:access-control>
              <user-hint>read-only</user-hint>
            </xsd:appinfo>
            <xsd:documentation>
              This data element specifies the basic call digit map.
            </xsd:documentation>
          </xsd:annotation>
        </xsd:element>
        <xsd:element name="pktcRSTBasicCallSDP" type="SNMP-FRAMEWORK-
MIB:SnmpAdminString">
          <xsd:annotation>
            <xsd:appinfo>
              <maxAccess>read-write</maxAccess>
              <oid>1.3.6.1.4.1.4491.2.2.7.4.1.3.1.2</oid>
              <status>current</status>
              <PKTC-ACLS:access-control>NetworkWritable</PKTC-ACLS:access-control>
              <user-hint>read-only</user-hint>
            </xsd:appinfo>
            <xsd:documentation>
              This data element specifies the SDP parameters and value.
            </xsd:documentation>
          </xsd:annotation>
        </xsd:element>
        <xsd:element name="pktcRSTBasicCallByeDelay" type="smi:Integer32">
          <xsd:annotation>
            <xsd:appinfo>
              <maxAccess>read-write</maxAccess>
              <oid>1.3.6.1.4.1.4491.2.2.7.4.1.3.1.3</oid>
              <status>current</status>
              <PKTC-ACLS:access-control>NetworkWritable</PKTC-ACLS:access-control>
              <user-hint>read-only</user-hint>
            </xsd:appinfo>
            <xsd:documentation>
              This data element specifies the Bye Delay in seconds.
            </xsd:documentation>
          </xsd:annotation>
        </xsd:element>
      </xsd:sequence>
    </xsd:extension>
  </xsd:complexContent>
</complexType>

```

```
</xsd:element>
<xsd:element name="pktcRSTBasicCallOrigDTTimer" type="smi:Integer32">
  <xsd:annotation>
    <xsd:appinfo>
      <maxAccess>read-write</maxAccess>
      <oid>1.3.6.1.4.1.4491.2.2.7.4.1.3.1.4</oid>
      <status>current</status>
      <PKTC-ACLS:access-control>NetworkWritable</PKTC-ACLS:access-control>
      <user-hint>read-only</user-hint>
    </xsd:appinfo>
    <xsd:documentation>
      This data element specifies the Origination Mode
      Dial Tone Timer in seconds.
    </xsd:documentation>
  </xsd:annotation>
</xsd:element>
<xsd:element name="pktcRSTBasicCallTermOHErrorSignal"
type="PktcRSTTONEANNC">
  <xsd:annotation>
    <xsd:appinfo>
      <maxAccess>read-write</maxAccess>
      <oid>1.3.6.1.4.1.4491.2.2.7.4.1.3.1.5</oid>
      <status>current</status>
      <PKTC-ACLS:access-control>NetworkWritable</PKTC-ACLS:access-control>
      <user-hint>read-only</user-hint>
    </xsd:appinfo>
    <xsd:documentation>
      This data element specifies the Termination Mode Off-Hook
      error signal.
    </xsd:documentation>
  </xsd:annotation>
</xsd:element>
<xsd:element name="pktcRSTBasicCallTermErrSignalTimer"
type="smi:Integer32">
  <xsd:annotation>
    <xsd:appinfo>
      <maxAccess>read-write</maxAccess>
      <oid>1.3.6.1.4.1.4491.2.2.7.4.1.3.1.6</oid>
      <status>current</status>
      <PKTC-ACLS:access-control>NetworkWritable</PKTC-ACLS:access-control>
      <user-hint>read-only</user-hint>
    </xsd:appinfo>
    <xsd:documentation>
      This data element specifies the Termination Mode
      error signal timer in seconds.
    </xsd:documentation>
  </xsd:annotation>
</xsd:element>
<xsd:element name="pktcRSTBasicCallPermSeqTone1" type="PktcRSTTONEANNC">
  <xsd:annotation>
    <xsd:appinfo>
      <maxAccess>read-write</maxAccess>
      <oid>1.3.6.1.4.1.4491.2.2.7.4.1.3.1.7</oid>
      <status>current</status>
      <PKTC-ACLS:access-control>NetworkWritable</PKTC-ACLS:access-control>
      <user-hint>read-only</user-hint>
    </xsd:appinfo>
    <xsd:documentation>
      This data element specifies the Permanent Sequence
      tone 1.
    </xsd:documentation>
  </xsd:annotation>
</xsd:element>
<xsd:element name="pktcRSTBasicCallPermSeqTimer1" type="smi:Integer32">
  <xsd:annotation>
    <xsd:appinfo>
      <maxAccess>read-write</maxAccess>
```

```

    <oid>1.3.6.1.4.1.4491.2.2.7.4.1.3.1.8</oid>
    <status>current</status>
    <PKTC-ACLS:access-control>NetworkWritable</PKTC-ACLS:access-control>
    <user-hint>read-only</user-hint>
  </xsd:appinfo>
  <xsd:documentation>
    This data element specifies the Permanent Sequence
    timer 1 in seconds.
  </xsd:documentation>
</xsd:annotation>
</xsd:element>
<xsd:element name="pktcRSTBasicCallPermSeqTone2" type="PktcRSTTONEANNC">
  <xsd:annotation>
    <xsd:appinfo>
      <maxAccess>read-write</maxAccess>
      <oid>1.3.6.1.4.1.4491.2.2.7.4.1.3.1.9</oid>
      <status>current</status>
      <PKTC-ACLS:access-control>NetworkWritable</PKTC-ACLS:access-control>
      <user-hint>read-only</user-hint>
    </xsd:appinfo>
    <xsd:documentation>
      This data element specifies the Permanent Sequence
      tone 2.
    </xsd:documentation>
  </xsd:annotation>
</xsd:element>
<xsd:element name="pktcRSTBasicCallPermSeqTimer2" type="smi:Integer32">
  <xsd:annotation>
    <xsd:appinfo>
      <maxAccess>read-write</maxAccess>
      <oid>1.3.6.1.4.1.4491.2.2.7.4.1.3.1.10</oid>
      <status>current</status>
      <PKTC-ACLS:access-control>NetworkWritable</PKTC-ACLS:access-control>
      <user-hint>read-only</user-hint>
    </xsd:appinfo>
    <xsd:documentation>
      This data element specifies the Permanent Sequence
      timer 2 in seconds.
    </xsd:documentation>
  </xsd:annotation>
</xsd:element>
<xsd:element name="pktcRSTBasicCallPermSeqTone3" type="PktcRSTTONEANNC">
  <xsd:annotation>
    <xsd:appinfo>
      <maxAccess>read-write</maxAccess>
      <oid>1.3.6.1.4.1.4491.2.2.7.4.1.3.1.11</oid>
      <status>current</status>
      <PKTC-ACLS:access-control>NetworkWritable</PKTC-ACLS:access-control>
      <user-hint>read-only</user-hint>
    </xsd:appinfo>
    <xsd:documentation>
      This data element specifies the Permanent Sequence
      tone 3.
    </xsd:documentation>
  </xsd:annotation>
</xsd:element>
<xsd:element name="pktcRSTBasicCallPermSeqTimer3" type="smi:Integer32">
  <xsd:annotation>
    <xsd:appinfo>
      <maxAccess>read-write</maxAccess>
      <oid>1.3.6.1.4.1.4491.2.2.7.4.1.3.1.12</oid>
      <status>current</status>
      <PKTC-ACLS:access-control>NetworkWritable</PKTC-ACLS:access-control>
      <user-hint>read-only</user-hint>
    </xsd:appinfo>
    <xsd:documentation>
      This data element specifies the Permanent Sequence

```



```

    <PKTC-ACLS:access-control>NetworkWritable</PKTC-ACLS:access-control>
    <user-hint>read-only</user-hint>
  </xsd:appinfo>
  <xsd:documentation>
    This data element specifies the Announcement Domain.
  </xsd:documentation>
</xsd:annotation>
</xsd:element>
<xsd:element name="pktcRSTAncPath" type="SNMP-FRAMEWORK-
MIB:SnmpAdminString">
  <xsd:annotation>
    <xsd:appinfo>
      <maxAccess>read-write</maxAccess>
      <oid>1.3.6.1.4.1.4491.2.2.7.4.1.3.2.3</oid>
      <status>current</status>
      <PKTC-ACLS:access-control>NetworkWritable</PKTC-ACLS:access-control>
      <user-hint>read-only</user-hint>
    </xsd:appinfo>
    <xsd:documentation>
      This data element specifies the Announcement Path.
    </xsd:documentation>
  </xsd:annotation>
</xsd:element>
<xsd:element name="pktcRSTAncMIMETYPE" type="SNMP-FRAMEWORK-
MIB:SnmpAdminString">
  <xsd:annotation>
    <xsd:appinfo>
      <maxAccess>read-write</maxAccess>
      <oid>1.3.6.1.4.1.4491.2.2.7.4.1.3.2.4</oid>
      <status>current</status>
      <PKTC-ACLS:access-control>NetworkWritable</PKTC-ACLS:access-control>
      <user-hint>read-only</user-hint>
    </xsd:appinfo>
    <xsd:documentation>
      This data element specifies the Announcement MIME type.
    </xsd:documentation>
  </xsd:annotation>
</xsd:element>
<xsd:element name="pktcRSTAncMediaCachMaxAge" type="smi:Integer32"
minOccurs="0">
  <xsd:annotation>
    <xsd:appinfo>
      <maxAccess>read-write</maxAccess>
      <oid>1.3.6.1.4.1.4491.2.2.7.4.1.3.2.7</oid>
      <status>current</status>
      <PKTC-ACLS:access-control>NetworkWritable</PKTC-ACLS:access-control>
      <user-hint>read-only</user-hint>
    </xsd:appinfo>
    <xsd:documentation>
      This data element specifies the Announcement Media Cache
      maximum age in seconds.
    </xsd:documentation>
  </xsd:annotation>
</xsd:element>
<xsd:element name="eXTObjpktcRSTAncFeatProfile" type="CL-PKTC-
TC:PktcPACMExtension" minOccurs="0">
  <xsd:annotation>
    <xsd:appinfo>
      <maxAccess>read-only</maxAccess>
      <oid>1.3.6.1.4.1.4491.2.2.7.4.1.3.2.8</oid>
      <status>current</status>
      <PKTC-ACLS:access-control>NetworkWritable</PKTC-ACLS:access-control>
      <user-hint>RW</user-hint>
    </xsd:appinfo>
    <xsd:documentation>
      Extension object for 'pktcRSTAncFeatProfile'.
    </xsd:documentation>
  </xsd:annotation>

```



```

    </xsd:element>
    <xsd:any namespace="##other" processContents="lax" minOccurs="0"
maxOccurs="unbounded" />
  </xsd:sequence>
</xsd:extension>
</xsd:complexContent>
</xsd:complexType>
<xsd:complexType name="pktcRSTUEStatusChangeProfileType">
  <xsd:complexContent>
    <xsd:extension base="CL-PKTC-BASE-SVC:pktcPACMSvcFeature">
      <xsd:sequence>
        <xsd:element name="pktcRSTUEStRegExp" type="smi:Integer32" minOccurs="0">
          <xsd:annotation>
            <xsd:appinfo>
              <maxAccess>read-write</maxAccess>
              <oid>1.3.6.1.4.1.4491.2.2.7.4.1.3.5.1</oid>
              <status>current</status>
              <PKTC-ACLS:access-control>NetworkWritable</PKTC-ACLS:access-control>
              <user-hint>RW</user-hint>
            </xsd:appinfo>
            <xsd:documentation>
              This data element specifies the UE Status
              Registration expiration in seconds.
            </xsd:documentation>
          </xsd:annotation>
        </xsd:element>
        <xsd:element name="eXTOBJpktcRSTUEStatusChangeProfile" type="CL-PKTC-
TC:PktcPACMExtension" minOccurs="0">
          <xsd:annotation>
            <xsd:appinfo>
              <maxAccess>read-only</maxAccess>
              <oid>1.3.6.1.4.1.4491.2.2.7.4.1.3.5.3</oid>
              <status>current</status>
              <PKTC-ACLS:access-control>NetworkWritable</PKTC-ACLS:access-control>
              <user-hint>RW</user-hint>
            </xsd:appinfo>
            <xsd:documentation>
              Extension object for 'pktcRSTUEStatusChangeProfile'.
            </xsd:documentation>
          </xsd:annotation>
        </xsd:element>
      <xsd:any namespace="##other" processContents="lax" minOccurs="0"
maxOccurs="unbounded" />
    </xsd:sequence>
  </xsd:extension>
</xsd:complexContent>
</xsd:complexType>
<xsd:complexType name="pktcRSTNoAnsTimeoutProfileType">
  <xsd:complexContent>
    <xsd:extension base="CL-PKTC-BASE-SVC:pktcPACMSvcFeature">
      <xsd:sequence>
        <xsd:element name="pktcRSTNAnsTODuration" type="smi:Integer32">
          <xsd:annotation>
            <xsd:appinfo>
              <maxAccess>read-write</maxAccess>
              <oid>1.3.6.1.4.1.4491.2.2.7.4.1.3.6.1</oid>
              <status>current</status>
              <PKTC-ACLS:access-control>NetworkWritable</PKTC-ACLS:access-control>
              <user-hint>read-only</user-hint>
            </xsd:appinfo>
            <xsd:documentation>
              This data element specifies the No Answer Timeout Duration
              in seconds.
            </xsd:documentation>
          </xsd:annotation>
        </xsd:element>

```

```

        <xsd:element name="eXTOBJpktcRSTNoAnsTimeoutProfile" type="CL-PKTC-
TC:PktcPACMExtension" minOccurs="0">
        <xsd:annotation>
        <xsd:appinfo>
        <maxAccess>read-only</maxAccess>
        <oid>1.3.6.1.4.1.4491.2.2.7.4.1.3.6.2</oid>
        <status>current</status>
        <PKTC-ACLS:access-control>NetworkWritable</PKTC-ACLS:access-control>
        <user-hint>RW</user-hint>
        </xsd:appinfo>
        <xsd:documentation>
        Extension object for 'pktcRSTNoAnsTimeoutProfile'.
        </xsd:documentation>
        </xsd:annotation>
        </xsd:element>
        <xsd:any namespace="##other" processContents="lax" minOccurs="0"
maxOccurs="unbounded" />
        </xsd:sequence>
        </xsd:extension>
        </xsd:complexContent>
        </xsd:complexType>
        <xsd:complexType name="pktcRSTCallerIdProfileType">
        <xsd:complexContent>
        <xsd:extension base="CL-PKTC-BASE-SVC:pktcPACMSvcFeature">
        <xsd:sequence>
        <xsd:element name="pktcRSTCIDPPS" minOccurs="0">
        <xsd:annotation>
        <xsd:appinfo>
        <maxAccess>read-write</maxAccess>
        <oid>1.3.6.1.4.1.4491.2.2.7.4.1.3.7.1</oid>
        <status>current</status>
        <PKTC-ACLS:access-control>NetworkWritable</PKTC-ACLS:access-control>
        <user-hint>read-only</user-hint>
        </xsd:appinfo>
        <xsd:documentation>
        This data element specifies the Permanent Presentation Status.
        </xsd:documentation>
        </xsd:annotation>
        <xsd:simpleType>
        <xsd:restriction base="xsd:NMTOKEN">
        <xsd:enumeration value="anonymous">
        <xsd:annotation>
        <xsd:appinfo>
        <intVal>1</intVal>
        </xsd:appinfo>
        </xsd:annotation>
        </xsd:enumeration>
        <xsd:enumeration value="public">
        <xsd:annotation>
        <xsd:appinfo>
        <intVal>2</intVal>
        </xsd:appinfo>
        </xsd:annotation>
        </xsd:enumeration>
        </xsd:restriction>
        </xsd:simpleType>
        </xsd:element>
        <xsd:element name="eXTOBJpktcRSTCallerIdProfile" type="CL-PKTC-
TC:PktcPACMExtension" minOccurs="0">
        <xsd:annotation>
        <xsd:appinfo>
        <maxAccess>read-only</maxAccess>
        <oid>1.3.6.1.4.1.4491.2.2.7.4.1.3.7.2</oid>
        <status>current</status>
        <PKTC-ACLS:access-control>NetworkWritable</PKTC-ACLS:access-control>
        <user-hint>RW</user-hint>
        </xsd:appinfo>
    
```

```

    <xsd:documentation>
      Extension object for 'pktcRSTCallerIdProfile'.
    </xsd:documentation>
  </xsd:annotation>
</xsd:element>
<xsd:any namespace="##other" processContents="lax" minOccurs="0"
maxOccurs="unbounded" />
</xsd:sequence>
</xsd:extension>
</xsd:complexContent>
</xsd:complexType>
<xsd:complexType name="pktcRSTCIDDisplayProfileType">
  <xsd:complexContent>
    <xsd:extension base="CL-PKTC-BASE-SVC:pktcPACMSvcFeature">
      <xsd:sequence>
        <xsd:element name="pktcRSTCIDCNDActStatus" type="SNMPv2-TC:TruthValue">
          <xsd:annotation>
            <xsd:appinfo>
              <maxAccess>read-write</maxAccess>
              <oid>1.3.6.1.4.1.4491.2.2.7.4.1.3.8.1</oid>
              <status>current</status>
              <PKTC-ACLS:access-control>NetworkWritable</PKTC-ACLS:access-control>
              <user-hint>read-only</user-hint>
            </xsd:appinfo>
            <xsd:documentation>
              This data element specifies the activation status for Calling
              Number Display (CND).
            </xsd:documentation>
          </xsd:annotation>
        </xsd:element>
        <xsd:element name="pktcRSTCIDCNAMDActStatus" type="SNMPv2-TC:TruthValue">
          <xsd:annotation>
            <xsd:appinfo>
              <maxAccess>read-write</maxAccess>
              <oid>1.3.6.1.4.1.4491.2.2.7.4.1.3.8.2</oid>
              <status>current</status>
              <PKTC-ACLS:access-control>NetworkWritable</PKTC-ACLS:access-control>
              <user-hint>read-only</user-hint>
            </xsd:appinfo>
            <xsd:documentation>
              This data element specifies the activation status for Calling
              Name Display (CNAMD).
            </xsd:documentation>
          </xsd:annotation>
        </xsd:element>
        <xsd:element name="pktcRSTCIDDispTimeAdj" type="smi:Integer32">
          <xsd:annotation>
            <xsd:appinfo>
              <maxAccess>read-write</maxAccess>
              <oid>1.3.6.1.4.1.4491.2.2.7.4.1.3.8.3</oid>
              <status>current</status>
              <PKTC-ACLS:access-control>NetworkWritable</PKTC-ACLS:access-control>
              <user-hint>read-only</user-hint>
            </xsd:appinfo>
            <xsd:documentation>
              This data element specifies UTC time adjustment
              in minutes.
            </xsd:documentation>
          </xsd:annotation>
        </xsd:element>
        <xsd:element name="pktcRSTCIDDispDefCountry" type="SNMP-FRAMEWORK-
MIB:SnmpAdminString">
          <xsd:annotation>
            <xsd:appinfo>
              <maxAccess>read-write</maxAccess>
              <oid>1.3.6.1.4.1.4491.2.2.7.4.1.3.8.4</oid>
              <status>current</status>
            </xsd:appinfo>
          </xsd:annotation>
        </xsd:element>
      </xsd:sequence>
    </xsd:extension>
  </xsd:complexContent>
</xsd:complexType>

```

```
<PKTC-ACLS:access-control>NetworkWritable</PKTC-ACLS:access-control>
<user-hint>read-only</user-hint>
</xsd:appinfo>
<xsd:documentation>
  This data element specifies default country code.
</xsd:documentation>
</xsd:annotation>
</xsd:element>
<xsd:element name="eXTOBJpktcRSTCIDDisplayProfile" type="CL-PKTC-
TC:PktcPACMExtension" minOccurs="0">
  <xsd:annotation>
    <xsd:appinfo>
      <maxAccess>read-only</maxAccess>
      <oid>1.3.6.1.4.1.4491.2.2.7.4.1.3.8.5</oid>
      <status>current</status>
      <PKTC-ACLS:access-control>NetworkWritable</PKTC-ACLS:access-control>
      <user-hint>RW</user-hint>
    </xsd:appinfo>
    <xsd:documentation>
      Extension object for 'pktcRSTCIDDisplayProfile'.
    </xsd:documentation>
  </xsd:annotation>
</xsd:element>
<xsd:any namespace="##other" processContents="lax" minOccurs="0"
maxOccurs="unbounded"/>
</xsd:sequence>
</xsd:extension>
</xsd:complexContent>
</xsd:complexType>
<xsd:complexType name="pktcRSTCIDCallBlkProfileType">
  <xsd:complexContent>
    <xsd:extension base="CL-PKTC-BASE-SVC:pktcPACMSvcFeature">
      <xsd:sequence>
        <xsd:element name="pktcRSTCIDBlkConfTone" type="PktcRSTTONEANNC">
          <xsd:annotation>
            <xsd:appinfo>
              <maxAccess>read-write</maxAccess>
              <oid>1.3.6.1.4.1.4491.2.2.7.4.1.3.9.1</oid>
              <status>current</status>
              <PKTC-ACLS:access-control>NetworkWritable</PKTC-ACLS:access-control>
              <user-hint>read-only</user-hint>
            </xsd:appinfo>
            <xsd:documentation>
              This data element specifies the confirmation tone after
              vertical feature code.
            </xsd:documentation>
          </xsd:annotation>
        </xsd:element>
        <xsd:element name="pktcRSTCIDBlkErrTone" type="PktcRSTTONEANNC">
          <xsd:annotation>
            <xsd:appinfo>
              <maxAccess>read-write</maxAccess>
              <oid>1.3.6.1.4.1.4491.2.2.7.4.1.3.9.2</oid>
              <status>current</status>
              <PKTC-ACLS:access-control>NetworkWritable</PKTC-ACLS:access-control>
              <user-hint>read-only</user-hint>
            </xsd:appinfo>
            <xsd:documentation>
              This data element specifies the error tone after
              vertical feature code failure.
            </xsd:documentation>
          </xsd:annotation>
        </xsd:element>
        <xsd:element name="eXTOBJpktcRSTCIDCallBlkProfile" type="CL-PKTC-
TC:PktcPACMExtension" minOccurs="0">
          <xsd:annotation>
            <xsd:appinfo>
```

```

    <maxAccess>read-only</maxAccess>
    <oid>1.3.6.1.4.1.4491.2.2.7.4.1.3.9.3</oid>
    <status>current</status>
    <PKTC-ACLS:access-control>NetworkWritable</PKTC-ACLS:access-control>
    <user-hint>RW</user-hint>
  </xsd:appinfo>
  <xsd:documentation>
    Extension object for 'pktcRSTCIDCallBlkProfile'.
  </xsd:documentation>
</xsd:annotation>
</xsd:element>
  <xsd:any namespace="##other" processContents="lax" minOccurs="0"
maxOccurs="unbounded" />
</xsd:sequence>
</xsd:extension>
</xsd:complexContent>
</xsd:complexType>
<xsd:complexType name="pktcRSTCIDCallDelProfileType">
  <xsd:complexContent>
    <xsd:extension base="CL-PKTC-BASE-SVC:pktcPACMSvcFeature">
      <xsd:sequence>
        <xsd:element name="pktcRSTCIDCDelConfTone" type="PktcRSTTONEANNC">
          <xsd:annotation>
            <xsd:appinfo>
              <maxAccess>read-write</maxAccess>
              <oid>1.3.6.1.4.1.4491.2.2.7.4.1.3.10.1</oid>
              <status>current</status>
              <PKTC-ACLS:access-control>NetworkWritable</PKTC-ACLS:access-control>
              <user-hint>read-only</user-hint>
            </xsd:appinfo>
            <xsd:documentation>
              This data element specifies the confirmation tone after
              vertical feature code.
            </xsd:documentation>
          </xsd:annotation>
        </xsd:element>
        <xsd:element name="pktcRSTCIDCDelErrTone" type="PktcRSTTONEANNC">
          <xsd:annotation>
            <xsd:appinfo>
              <maxAccess>read-write</maxAccess>
              <oid>1.3.6.1.4.1.4491.2.2.7.4.1.3.10.2</oid>
              <status>current</status>
              <PKTC-ACLS:access-control>NetworkWritable</PKTC-ACLS:access-control>
              <user-hint>read-only</user-hint>
            </xsd:appinfo>
            <xsd:documentation>
              This data element specifies the error tone after
              vertical feature code failure.
            </xsd:documentation>
          </xsd:annotation>
        </xsd:element>
        <xsd:element name="eXTOBJpktcRSTCIDCallDelProfile" type="CL-PKTC-
TC:PktcPACMExtension" minOccurs="0">
          <xsd:annotation>
            <xsd:appinfo>
              <maxAccess>read-only</maxAccess>
              <oid>1.3.6.1.4.1.4491.2.2.7.4.1.3.10.3</oid>
              <status>current</status>
              <PKTC-ACLS:access-control>NetworkWritable</PKTC-ACLS:access-control>
              <user-hint>RW</user-hint>
            </xsd:appinfo>
            <xsd:documentation>
              Extension object for 'pktcRSTCIDCallDelProfile'.
            </xsd:documentation>
          </xsd:annotation>
        </xsd:element>

```

```
<xsd:any namespace="##other" processContents="lax" minOccurs="0"
maxOccurs="unbounded" />
</xsd:sequence>
</xsd:extension>
</xsd:complexContent>
</xsd:complexType>
<xsd:complexType name="pktcRSTCFwdProfileType">
  <xsd:complexContent>
    <xsd:extension base="CL-PKTC-BASE-SVC:pktcPACMSvcFeature">
      <xsd:sequence>
        <xsd:element name="pktcRSTCFwdSpDialTone" type="SNMPv2-TC:TruthValue">
          <xsd:annotation>
            <xsd:appinfo>
              <maxAccess>read-write</maxAccess>
              <oid>1.3.6.1.4.1.4491.2.2.7.4.1.3.11.1</oid>
              <status>current</status>
              <PKTC-ACLS:access-control>NetworkWritable</PKTC-ACLS:access-control>
              <user-hint>read-only</user-hint>
            </xsd:appinfo>
            <xsd:documentation>
              This data element specifies the special conditions dial tone
              when forwarded indicator.
            </xsd:documentation>
          </xsd:annotation>
        </xsd:element>
        <xsd:element name="pktcRSTCFwdSubDuration" type="smi:Integer32">
          <xsd:annotation>
            <xsd:appinfo>
              <maxAccess>read-write</maxAccess>
              <oid>1.3.6.1.4.1.4491.2.2.7.4.1.3.11.2</oid>
              <status>current</status>
              <PKTC-ACLS:access-control>NetworkWritable</PKTC-ACLS:access-control>
              <user-hint>read-only</user-hint>
            </xsd:appinfo>
            <xsd:documentation>
              This data element specifies the subscription duration in seconds.
            </xsd:documentation>
          </xsd:annotation>
        </xsd:element>
        <xsd:element name="eXTObjpktcRSTCFwdProfile" type="CL-PKTC-
TC:PktcPACMExtension" minOccurs="0">
          <xsd:annotation>
            <xsd:appinfo>
              <maxAccess>read-only</maxAccess>
              <oid>1.3.6.1.4.1.4491.2.2.7.4.1.3.11.3</oid>
              <status>current</status>
              <PKTC-ACLS:access-control>NetworkWritable</PKTC-ACLS:access-control>
              <user-hint>RW</user-hint>
            </xsd:appinfo>
            <xsd:documentation>
              Extension object for 'pktcRSTCFwdProfile'.
            </xsd:documentation>
          </xsd:annotation>
        </xsd:element>
      </xsd:sequence>
    </xsd:extension>
  </xsd:complexContent>
</xsd:complexType>
<xsd:complexType name="pktcRSTCallWaitProfileType">
  <xsd:complexContent>
    <xsd:extension base="CL-PKTC-BASE-SVC:pktcPACMSvcFeature">
      <xsd:sequence>
        <xsd:element name="pktcRSTCWDisableStarCode" type="PktcRSTDIGITMAP">
          <xsd:annotation>
            <xsd:appinfo>
```

```

    <maxAccess>read-write</maxAccess>
    <oid>1.3.6.1.4.1.4491.2.2.7.4.1.3.12.1</oid>
    <status>current</status>
    <PKTC-ACLS:access-control>NetworkWritable</PKTC-ACLS:access-control>
    <user-hint>read-only</user-hint>
  </xsd:appinfo>
  <xsd:documentation>
    This data element specifies the per call call-waiting
    disable star code.
  </xsd:documentation>
</xsd:annotation>
</xsd:element>
<xsd:element name="eXTOBJpktcRSTCallWaitProfile" type="CL-PKTC-
TC:PktcPACMExtension" minOccurs="0">
  <xsd:annotation>
    <xsd:appinfo>
      <maxAccess>read-only</maxAccess>
      <oid>1.3.6.1.4.1.4491.2.2.7.4.1.3.12.2</oid>
      <status>current</status>
      <PKTC-ACLS:access-control>NetworkWritable</PKTC-ACLS:access-control>
      <user-hint>RW</user-hint>
    </xsd:appinfo>
    <xsd:documentation>
      Extension object for 'pktcRSTCallWaitProfile'.
    </xsd:documentation>
  </xsd:annotation>
</xsd:element>
<xsd:any namespace="##other" processContents="lax" minOccurs="0"
maxOccurs="unbounded"/>
</xsd:sequence>
</xsd:extension>
</xsd:complexType>
<xsd:complexType name="pktcRSTCallHoldProfileType">
  <xsd:complexContent>
    <xsd:extension base="CL-PKTC-BASE-SVC:pktcPACMSvcFeature">
      <xsd:sequence>
        <xsd:element name="pktcRSTCHFeatCode" type="SNMP-FRAMEWORK-
MIB:SnmpAdminString">
          <xsd:annotation>
            <xsd:appinfo>
              <maxAccess>read-write</maxAccess>
              <oid>1.3.6.1.4.1.4491.2.2.7.4.1.3.13.1</oid>
              <status>current</status>
              <PKTC-ACLS:access-control>NetworkWritable</PKTC-ACLS:access-control>
              <user-hint>read-only</user-hint>
            </xsd:appinfo>
            <xsd:documentation>
              This data element specifies the Call Hold Feature Code.
            </xsd:documentation>
          </xsd:annotation>
        </xsd:element>
        <xsd:element name="pktcRSTCHFeatConfirm" type="PktcRSTTONEANNC">
          <xsd:annotation>
            <xsd:appinfo>
              <maxAccess>read-write</maxAccess>
              <oid>1.3.6.1.4.1.4491.2.2.7.4.1.3.13.2</oid>
              <status>current</status>
              <PKTC-ACLS:access-control>NetworkWritable</PKTC-ACLS:access-control>
              <user-hint>read-only</user-hint>
            </xsd:appinfo>
            <xsd:documentation>
              This data element specifies the feature activation/deactivation
              confirmation indicator.
            </xsd:documentation>
          </xsd:annotation>
        </xsd:element>
      </xsd:sequence>
    </xsd:extension>
  </xsd:complexContent>
</xsd:complexType>

```

```

        <xsd:element name="eXTOBJpktcRSTCallHoldProfile" type="CL-PKTC-
    TC:PktcPACMExtension" minOccurs="0">
        <xsd:annotation>
        <xsd:appinfo>
            <maxAccess>read-only</maxAccess>
            <oid>1.3.6.1.4.1.4491.2.2.7.4.1.3.13.3</oid>
            <status>current</status>
            <PKTC-ACLS:access-control>NetworkWritable</PKTC-ACLS:access-control>
            <user-hint>RW</user-hint>
        </xsd:appinfo>
        <xsd:documentation>
            Extension object for 'pktcRSTCallHoldProfile'.
        </xsd:documentation>
        </xsd:annotation>
        </xsd:element>
        <xsd:any namespace="##other" processContents="lax" minOccurs="0"
    maxOccurs="unbounded" />
    </xsd:sequence>
    </xsd:extension>
    </xsd:complexContent>
    </xsd:complexType>
    <xsd:complexType name="pktcRSTCallTransProfileType">
        <xsd:complexContent>
            <xsd:extension base="CL-PKTC-BASE-SVC:pktcPACMSvcFeature">
                <xsd:sequence>
                    <xsd:element name="pktcRSTCTNotifyTimeout" type="smi:Integer32">
                        <xsd:annotation>
                            <xsd:appinfo>
                                <maxAccess>read-write</maxAccess>
                                <oid>1.3.6.1.4.1.4491.2.2.7.4.1.3.14.1</oid>
                                <status>current</status>
                                <PKTC-ACLS:access-control>NetworkWritable</PKTC-ACLS:access-control>
                                <user-hint>read-only</user-hint>
                            </xsd:appinfo>
                            <xsd:documentation>
                                This data element specifies the Notify
                                Timeout in seconds.
                            </xsd:documentation>
                        </xsd:annotation>
                    </xsd:element>
                    <xsd:element name="eXTOBJpktcRSTCallTransProfile" type="CL-PKTC-
    TC:PktcPACMExtension" minOccurs="0">
                        <xsd:annotation>
                            <xsd:appinfo>
                                <maxAccess>read-only</maxAccess>
                                <oid>1.3.6.1.4.1.4491.2.2.7.4.1.3.14.2</oid>
                                <status>current</status>
                                <PKTC-ACLS:access-control>NetworkWritable</PKTC-ACLS:access-control>
                                <user-hint>RW</user-hint>
                            </xsd:appinfo>
                            <xsd:documentation>
                                Extension object for 'pktcRSTCallTransProfile'.
                            </xsd:documentation>
                        </xsd:annotation>
                    </xsd:element>
                    <xsd:any namespace="##other" processContents="lax" minOccurs="0"
                maxOccurs="unbounded" />
                </xsd:sequence>
                </xsd:extension>
                </xsd:complexContent>
                </xsd:complexType>
                <xsd:complexType name="pktcRST3WCFeatureProfileType">
                    <xsd:complexContent>
                        <xsd:extension base="CL-PKTC-BASE-SVC:pktcPACMSvcFeature">
                            <xsd:sequence>
                                <xsd:element name="eXTOBJpktcRST3WCFeatureProfile" type="CL-PKTC-
                TC:PktcPACMExtension" minOccurs="0">

```

```

    <xsd:annotation>
      <xsd:appinfo>
        <maxAccess>read-only</maxAccess>
        <oid>1.3.6.1.4.1.4491.2.2.7.4.1.3.15.1</oid>
        <status>current</status>
        <PKTC-ACLS:access-control>NetworkWritable</PKTC-ACLS:access-control>
        <user-hint>RW</user-hint>
      </xsd:appinfo>
      <xsd:documentation>
        Extension object for 'pktcRST3WCFeatureProfile'.
      </xsd:documentation>
    </xsd:annotation>
  </xsd:element>
  <xsd:any namespace="##other" processContents="lax" minOccurs="0"
maxOccurs="unbounded" />
</xsd:sequence>
</xsd:extension>
</xsd:complexContent>
</xsd:complexType>
<xsd:complexType name="pktcRSTDNDProfileType">
  <xsd:complexContent>
    <xsd:extension base="CL-PKTC-BASE-SVC:pktcPACMSvcFeature">
      <xsd:sequence>
        <xsd:element name="pktcRSTDNDActConfirm" type="PktcRSTTONEANNC">
          <xsd:annotation>
            <xsd:appinfo>
              <maxAccess>read-write</maxAccess>
              <oid>1.3.6.1.4.1.4491.2.2.7.4.1.3.16.1</oid>
              <status>current</status>
              <PKTC-ACLS:access-control>NetworkWritable</PKTC-ACLS:access-control>
              <user-hint>read-only</user-hint>
            </xsd:appinfo>
            <xsd:documentation>
              This data element specifies the Feature Activation Confirmation
Indicator.
            </xsd:documentation>
          </xsd:annotation>
        </xsd:element>
        <xsd:element name="pktcRSTDNDDeActConfirm" type="PktcRSTTONEANNC">
          <xsd:annotation>
            <xsd:appinfo>
              <maxAccess>read-write</maxAccess>
              <oid>1.3.6.1.4.1.4491.2.2.7.4.1.3.16.2</oid>
              <status>current</status>
              <PKTC-ACLS:access-control>NetworkWritable</PKTC-ACLS:access-control>
              <user-hint>read-only</user-hint>
            </xsd:appinfo>
            <xsd:documentation>
              This data element specifies the Feature Deactivation Confirmation
Indicator.
            </xsd:documentation>
          </xsd:annotation>
        </xsd:element>
        <xsd:element name="eXTOBJpktcRSTDNDProfile" type="CL-PKTC-
TC:PktcPACMExtension" minOccurs="0">
          <xsd:annotation>
            <xsd:appinfo>
              <maxAccess>read-only</maxAccess>
              <oid>1.3.6.1.4.1.4491.2.2.7.4.1.3.16.3</oid>
              <status>current</status>
              <PKTC-ACLS:access-control>NetworkWritable</PKTC-ACLS:access-control>
              <user-hint>RW</user-hint>
            </xsd:appinfo>
            <xsd:documentation>
              Extension object for 'pktcRSTDNDProfile'.
            </xsd:documentation>
          </xsd:annotation>
        </xsd:element>
      </xsd:sequence>
    </xsd:extension>
  </xsd:complexContent>
</xsd:complexType>

```

```
</xsd:element>
  <xsd:any namespace="##other" processContents="lax" minOccurs="0"
maxOccurs="unbounded" />
</xsd:sequence>
</xsd:extension>
</xsd:complexContent>
</xsd:complexType>
<xsd:complexType name="pktcRSTSubProgPINProfileType">
  <xsd:complexContent>
    <xsd:extension base="CL-PKTC-BASE-SVC:pktcPACMSvcFeature">
      <xsd:sequence>
        <xsd:element name="eXTOBJpktcRSTSubProgPINProfile" type="CL-PKTC-
TC:PktcPACMExtension" minOccurs="0">
          <xsd:annotation>
            <xsd:appinfo>
              <maxAccess>read-only</maxAccess>
              <oid>1.3.6.1.4.1.4491.2.2.7.4.1.3.17.1</oid>
              <status>current</status>
              <PKTC-ACLS:access-control>NetworkWritable</PKTC-ACLS:access-control>
              <user-hint>RW</user-hint>
            </xsd:appinfo>
            <xsd:documentation>
              Extension object for 'pktcRSTSubProgPINProfile'.
            </xsd:documentation>
          </xsd:annotation>
        </xsd:element>
      <xsd:any namespace="##other" processContents="lax" minOccurs="0"
maxOccurs="unbounded" />
</xsd:sequence>
</xsd:extension>
</xsd:complexContent>
</xsd:complexType>
<xsd:complexType name="pktcRSTMWIProfileType">
  <xsd:complexContent>
    <xsd:extension base="CL-PKTC-BASE-SVC:pktcPACMSvcFeature">
      <xsd:sequence>
        <xsd:element name="pktcRSTSubDuration" type="smi:Integer32">
          <xsd:annotation>
            <xsd:appinfo>
              <maxAccess>read-write</maxAccess>
              <oid>1.3.6.1.4.1.4491.2.2.7.4.1.3.18.1</oid>
              <status>current</status>
              <PKTC-ACLS:access-control>NetworkWritable</PKTC-ACLS:access-control>
              <user-hint>RW</user-hint>
            </xsd:appinfo>
            <xsd:documentation>
              This data element specifies the MWI Subscription duration.
            </xsd:documentation>
          </xsd:annotation>
        </xsd:element>
        <xsd:element name="eXTOBJpktcRSTMWIProfile" type="CL-PKTC-
TC:PktcPACMExtension" minOccurs="0">
          <xsd:annotation>
            <xsd:appinfo>
              <maxAccess>read-only</maxAccess>
              <oid>1.3.6.1.4.1.4491.2.2.7.4.1.3.18.2</oid>
              <status>current</status>
              <PKTC-ACLS:access-control>NetworkWritable</PKTC-ACLS:access-control>
              <user-hint>RW</user-hint>
            </xsd:appinfo>
            <xsd:documentation>
              Extension object for 'pktcRSTMWIProfile'.
            </xsd:documentation>
          </xsd:annotation>
        </xsd:element>
      <xsd:any namespace="##other" processContents="lax" minOccurs="0"
maxOccurs="unbounded" />
```

```

    </xsd:sequence>
  </xsd:extension>
</xsd:complexContent>
</xsd:complexType>
<xsd:complexType name="pktcRSTAutoRecallProfileType">
  <xsd:complexContent>
    <xsd:extension base="CL-PKTC-BASE-SVC:pktcPACMSvcFeature">
      <xsd:sequence>
        <xsd:element name="pktcRSTARTimer" default="30" minOccurs="0">
          <xsd:annotation>
            <xsd:appinfo>
              <maxAccess>read-write</maxAccess>
              <oid>1.3.6.1.4.1.4491.2.2.7.4.1.3.19.1</oid>
              <status>current</status>
              <default>30</default>
              <PKTC-ACLS:access-control>NetworkWritable</PKTC-ACLS:access-control>
              <user-hint>read-only</user-hint>
            </xsd:appinfo>
            <xsd:documentation>
              This data element specifies the auto recall timer.
              This is minutes of feature duration.
            </xsd:documentation>
          </xsd:annotation>
          <xsd:simpleType>
            <xsd:restriction base="smi:Integer32">
              <xsd:minInclusive value="0"/>
              <xsd:maxInclusive value="30"/>
            </xsd:restriction>
          </xsd:simpleType>
        </xsd:element>
        <xsd:element name="pktcRSTARSpRingDuration" type="smi:Integer32">
          <xsd:annotation>
            <xsd:appinfo>
              <maxAccess>read-write</maxAccess>
              <oid>1.3.6.1.4.1.4491.2.2.7.4.1.3.19.2</oid>
              <status>current</status>
              <PKTC-ACLS:access-control>NetworkWritable</PKTC-ACLS:access-control>
              <user-hint>read-only</user-hint>
            </xsd:appinfo>
            <xsd:documentation>
              This data element specifies the auto recall special ring duration.
              This is the number of special ringing ring cycles.
            </xsd:documentation>
          </xsd:annotation>
        </xsd:element>
        <xsd:element name="pktcRSTARSpRingRetryTime" type="smi:Integer32">
          <xsd:annotation>
            <xsd:appinfo>
              <maxAccess>read-write</maxAccess>
              <oid>1.3.6.1.4.1.4491.2.2.7.4.1.3.19.3</oid>
              <status>current</status>
              <PKTC-ACLS:access-control>NetworkWritable</PKTC-ACLS:access-control>
              <user-hint>read-only</user-hint>
            </xsd:appinfo>
            <xsd:documentation>
              This data element specifies the auto recall special ringing retry
              wait interval. This is seconds to wait between attempts to alert
              the user with special ringing.
            </xsd:documentation>
          </xsd:annotation>
        </xsd:element>
        <xsd:element name="pktcRSTARSpRingRetries" type="smi:Integer32">
          <xsd:annotation>
            <xsd:appinfo>
              <maxAccess>read-write</maxAccess>
              <oid>1.3.6.1.4.1.4491.2.2.7.4.1.3.19.4</oid>
              <status>current</status>
            </xsd:appinfo>
          </xsd:annotation>
        </xsd:element>
      </xsd:sequence>
    </xsd:extension>
  </xsd:complexType>

```

```

        <PKTC-ACLS:access-control>NetworkWritable</PKTC-ACLS:access-control>
        <user-hint>read-only</user-hint>
    </xsd:appinfo>
    <xsd:documentation>
        This data element specifies the number of auto recall special
ringing
        retries.
        This is the number of times to retry special ringing before
canceling
        the AR request.
    </xsd:documentation>
</xsd:annotation>
</xsd:element>
<xsd:element name="pktcRSTARMaxSubSend" type="smi:Integer32">
    <xsd:annotation>
        <xsd:appinfo>
            <maxAccess>read-write</maxAccess>
            <oid>1.3.6.1.4.1.4491.2.2.7.4.1.3.19.5</oid>
            <status>current</status>
            <PKTC-ACLS:access-control>NetworkWritable</PKTC-ACLS:access-control>
            <user-hint>read-only</user-hint>
        </xsd:appinfo>
        <xsd:documentation>
            This data element specifies the maximum number of simultaneous
            subscribes the UE should send.
        </xsd:documentation>
    </xsd:annotation>
</xsd:element>
<xsd:element name="pktcRSTARMaxSubRec" type="smi:Integer32">
    <xsd:annotation>
        <xsd:appinfo>
            <maxAccess>read-write</maxAccess>
            <oid>1.3.6.1.4.1.4491.2.2.7.4.1.3.19.6</oid>
            <status>current</status>
            <PKTC-ACLS:access-control>NetworkWritable</PKTC-ACLS:access-control>
            <user-hint>read-only</user-hint>
        </xsd:appinfo>
        <xsd:documentation>
            This data element specifies the maximum number of simultaneous
            subscriptions the UE should honor.
        </xsd:documentation>
    </xsd:annotation>
</xsd:element>
<xsd:element name="eXTOBJpktcRSTAutoRecallProfile" type="CL-PKTC-
TC:PktcPACMExtension" minOccurs="0">
    <xsd:annotation>
        <xsd:appinfo>
            <maxAccess>read-only</maxAccess>
            <oid>1.3.6.1.4.1.4491.2.2.7.4.1.3.19.7</oid>
            <status>current</status>
            <PKTC-ACLS:access-control>NetworkWritable</PKTC-ACLS:access-control>
            <user-hint>RW</user-hint>
        </xsd:appinfo>
        <xsd:documentation>
            Extension object for 'pktcRSTAutoRecallProfile'.
        </xsd:documentation>
    </xsd:annotation>
</xsd:element>
<xsd:any namespace="##other" processContents="lax" minOccurs="0"
maxOccurs="unbounded"/>
</xsd:sequence>
</xsd:extension>
</xsd:complexContent>
</xsd:complexType>
<xsd:complexType name="pktcRSTAutoCallbackProfileType">
    <xsd:complexContent>
        <xsd:extension base="CL-PKTC-BASE-SVC:pktcPACMSvcFeature">

```

```

<xsd:sequence>
  <xsd:element name="pktcRSTACbTimer" default="30" minOccurs="0">
    <xsd:annotation>
      <xsd:appinfo>
        <maxAccess>read-write</maxAccess>
        <oid>1.3.6.1.4.1.4491.2.2.7.4.1.3.20.1</oid>
        <status>current</status>
        <default>30</default>
        <PKTC-ACLS:access-control>NetworkWritable</PKTC-ACLS:access-control>
        <user-hint>read-only</user-hint>
      </xsd:appinfo>
      <xsd:documentation>
        This data element specifies the auto callback timer.
        This is minutes of feature duration. 0-30min. Default=30
      </xsd:documentation>
    </xsd:annotation>
    <xsd:simpleType>
      <xsd:restriction base="smi:Integer32">
        <xsd:minInclusive value="0"/>
        <xsd:maxInclusive value="30"/>
      </xsd:restriction>
    </xsd:simpleType>
  </xsd:element>
  <xsd:element name="pktcRSTACbSpRingDuration" type="smi:Integer32">
    <xsd:annotation>
      <xsd:appinfo>
        <maxAccess>read-write</maxAccess>
        <oid>1.3.6.1.4.1.4491.2.2.7.4.1.3.20.2</oid>
        <status>current</status>
        <PKTC-ACLS:access-control>NetworkWritable</PKTC-ACLS:access-control>
        <user-hint>read-only</user-hint>
      </xsd:appinfo>
      <xsd:documentation>
        This data element specifies the auto callback special ring duration.
        This is the number of special ringing ring cycles.
      </xsd:documentation>
    </xsd:annotation>
  </xsd:element>
  <xsd:element name="pktcRSTACbSpRingRetryTime" type="smi:Integer32">
    <xsd:annotation>
      <xsd:appinfo>
        <maxAccess>read-write</maxAccess>
        <oid>1.3.6.1.4.1.4491.2.2.7.4.1.3.20.3</oid>
        <status>current</status>
        <PKTC-ACLS:access-control>NetworkWritable</PKTC-ACLS:access-control>
        <user-hint>read-only</user-hint>
      </xsd:appinfo>
      <xsd:documentation>
        This data element specifies the auto callback special ringing retry
        wait interval. This is seconds to wait between attempts to alert
        the user with special ringing.
      </xsd:documentation>
    </xsd:annotation>
  </xsd:element>
  <xsd:element name="pktcRSTACbSpRingRetries" type="smi:Integer32">
    <xsd:annotation>
      <xsd:appinfo>
        <maxAccess>read-write</maxAccess>
        <oid>1.3.6.1.4.1.4491.2.2.7.4.1.3.20.4</oid>
        <status>current</status>
        <PKTC-ACLS:access-control>NetworkWritable</PKTC-ACLS:access-control>
        <user-hint>read-only</user-hint>
      </xsd:appinfo>
      <xsd:documentation>
        This data element specifies the number of auto callback special
        ringing retries.

```

This is the number of times to retry special ringing before canceling the AR request.

```
</xsd:documentation>
</xsd:annotation>
</xsd:element>
<xsd:element name="pktcRSTACbMaxSubSend" type="smi:Integer32">
  <xsd:annotation>
    <xsd:appinfo>
      <maxAccess>read-write</maxAccess>
      <oid>1.3.6.1.4.1.4491.2.2.7.4.1.3.20.5</oid>
      <status>current</status>
      <PKTC-ACLS:access-control>NetworkWritable</PKTC-ACLS:access-control>
      <user-hint>read-only</user-hint>
    </xsd:appinfo>
    <xsd:documentation>
      This data element specifies the maximum number of simultaneous
      subscribes the UE should send..
    </xsd:documentation>
  </xsd:annotation>
</xsd:element>
<xsd:element name="pktcRSTACbMaxSubRec" type="smi:Integer32">
  <xsd:annotation>
    <xsd:appinfo>
      <maxAccess>read-write</maxAccess>
      <oid>1.3.6.1.4.1.4491.2.2.7.4.1.3.20.6</oid>
      <status>current</status>
      <PKTC-ACLS:access-control>NetworkWritable</PKTC-ACLS:access-control>
      <user-hint>read-only</user-hint>
    </xsd:appinfo>
    <xsd:documentation>
      This data element specifies the maximum number of simultaneous
      subscriptions
      the UE should honor.
    </xsd:documentation>
  </xsd:annotation>
</xsd:element>
<xsd:element name="eXTOBJpktcRSTAutoCallbackProfile" type="CL-PKTC-
TC:PktcPACMExtension" minOccurs="0">
  <xsd:annotation>
    <xsd:appinfo>
      <maxAccess>read-only</maxAccess>
      <oid>1.3.6.1.4.1.4491.2.2.7.4.1.3.20.7</oid>
      <status>current</status>
      <PKTC-ACLS:access-control>NetworkWritable</PKTC-ACLS:access-control>
      <user-hint>RW</user-hint>
    </xsd:appinfo>
    <xsd:documentation>
      Extension object for 'pktcRSTAutoCallbackProfile'.
    </xsd:documentation>
  </xsd:annotation>
</xsd:element>
<xsd:any namespace="##other" processContents="lax" minOccurs="0"
maxOccurs="unbounded"/>
</xsd:sequence>
</xsd:extension>
</xsd:complexContent>
</xsd:complexType>
<xsd:complexType name="pktcRSTBusyLineProfileType">
  <xsd:complexContent>
    <xsd:extension base="CL-PKTC-BASE-SVC:pktcPACMSvcFeature">
      <xsd:sequence>
        <xsd:element name="pktcRSTBusyLineVOperId" type="SNMP-FRAMEWORK-
MIB:SnmpAdminString">
          <xsd:annotation>
            <xsd:appinfo>
              <maxAccess>read-write</maxAccess>
```

```

    <oid>1.3.6.1.4.1.4491.2.2.7.4.1.3.21.1</oid>
    <status>current</status>
    <PKTC-ACLS:access-control>NetworkWritable</PKTC-ACLS:access-control>
    <user-hint>read-only</user-hint>
  </xsd:appinfo>
  <xsd:documentation>
    This data element specifies the Busy Line Verify Operator Id.
  </xsd:documentation>
</xsd:annotation>
</xsd:element>
<xsd:element name="eXTOBJpktcRSTBusyLineProfile" type="CL-PKTC-
TC:PktcPACMExtension" minOccurs="0">
  <xsd:annotation>
    <xsd:appinfo>
      <maxAccess>read-only</maxAccess>
      <oid>1.3.6.1.4.1.4491.2.2.7.4.1.3.21.2</oid>
      <status>current</status>
      <PKTC-ACLS:access-control>NetworkWritable</PKTC-ACLS:access-control>
      <user-hint>RW</user-hint>
    </xsd:appinfo>
    <xsd:documentation>
      Extension object for 'pktcRSTBusyLineProfile'.
    </xsd:documentation>
  </xsd:annotation>
</xsd:element>
<xsd:any namespace="##other" processContents="lax" minOccurs="0"
maxOccurs="unbounded" />
</xsd:sequence>
</xsd:extension>
</xsd:complexContent>
</xsd:complexType>
<xsd:complexType name="pktcRSTEmSvcProfileType">
  <xsd:complexContent>
    <xsd:extension base="CL-PKTC-BASE-SVC:pktcPACMSvcFeature">
      <xsd:sequence>
        <xsd:element name="pktcRSTEmSvcNwHoldTimer" type="smi:Integer32"
default="45">
          <xsd:annotation>
            <xsd:appinfo>
              <maxAccess>read-write</maxAccess>
              <oid>1.3.6.1.4.1.4491.2.2.7.4.1.3.22.1</oid>
              <status>current</status>
              <default>45</default>
              <PKTC-ACLS:access-control>NetworkWritable</PKTC-ACLS:access-control>
              <user-hint>read-only</user-hint>
            </xsd:appinfo>
            <xsd:documentation>
              This data element specifies the Emergency Services network hold
              timer in minutes.
            </xsd:documentation>
          </xsd:annotation>
        </xsd:element>
        <xsd:element name="pktcRSTEmSvcHowlTimer" type="smi:Integer32" default="3">
          <xsd:annotation>
            <xsd:appinfo>
              <maxAccess>read-write</maxAccess>
              <oid>1.3.6.1.4.1.4491.2.2.7.4.1.3.22.2</oid>
              <status>current</status>
              <default>3</default>
              <PKTC-ACLS:access-control>NetworkWritable</PKTC-ACLS:access-control>
              <user-hint>read-only</user-hint>
            </xsd:appinfo>
            <xsd:documentation>
              This data element specifies the Emergency Services howler
              timer in seconds.
            </xsd:documentation>
          </xsd:annotation>
        </xsd:element>
      </xsd:sequence>
    </xsd:extension>
  </xsd:complexContent>
</xsd:complexType>

```

```
</xsd:element>
<xsd:element name="pktcRSTEmSvcMediaDSCPVal" minOccurs="0">
  <xsd:annotation>
    <xsd:appinfo>
      <maxAccess>read-write</maxAccess>
      <oid>1.3.6.1.4.1.4491.2.2.7.4.1.3.22.3</oid>
      <status>current</status>
      <PKTC-ACLS:access-control>NetworkWritable</PKTC-ACLS:access-control>
      <user-hint>read-only</user-hint>
    </xsd:appinfo>
    <xsd:documentation>
      This data element specifies the Emergency Services emergency media
      DSCP value.
    </xsd:documentation>
  </xsd:annotation>
  <xsd:simpleType>
    <xsd:restriction base="smi:Integer32">
      <xsd:minInclusive value="0"/>
      <xsd:maxInclusive value="63"/>
    </xsd:restriction>
  </xsd:simpleType>
</xsd:element>
<xsd:element name="eXTOBJpktcRSTEmSvcProfile" type="CL-PKTC-
TC:PktcPACMExtension" minOccurs="0">
  <xsd:annotation>
    <xsd:appinfo>
      <maxAccess>read-only</maxAccess>
      <oid>1.3.6.1.4.1.4491.2.2.7.4.1.3.22.4</oid>
      <status>current</status>
      <PKTC-ACLS:access-control>NetworkWritable</PKTC-ACLS:access-control>
      <user-hint>RW</user-hint>
    </xsd:appinfo>
    <xsd:documentation>
      Extension object for 'pktcRSTEmSvcProfile'.
    </xsd:documentation>
  </xsd:annotation>
</xsd:element>
<xsd:any namespace="##other" processContents="lax" minOccurs="0"
maxOccurs="unbounded"/>
</xsd:sequence>
</xsd:extension>
</xsd:complexType>
<xsd:complexType name="pktcRSTAncMapEntryType">
  <xsd:complexContent>
    <xsd:extension base="CL-PKTC-BASE-SVC:pktcPACMSvcFeature">
      <xsd:sequence>
        <xsd:element name="pktcRSTAncURI" type="SNMP-FRAMEWORK-
MIB:SnmpAdminString">
          <xsd:annotation>
            <xsd:appinfo>
              <maxAccess>read-write</maxAccess>
              <oid>1.3.6.1.4.1.4491.2.2.7.4.1.3.2.5.1.2</oid>
              <status>current</status>
              <PKTC-ACLS:access-control>NetworkWritable</PKTC-ACLS:access-control>
              <user-hint>read-only</user-hint>
            </xsd:appinfo>
            <xsd:documentation>
              This data element specifies the Announcement Map entry.
              A string identifying the URI for response code.
            </xsd:documentation>
          </xsd:annotation>
        </xsd:element>
      <xsd:element name="eXTOBJpktcRSTAncMapEntry" type="CL-PKTC-
TC:PktcPACMExtension" minOccurs="0">
        <xsd:annotation>
          <xsd:appinfo>
```

```

    <maxAccess>read-only</maxAccess>
    <oid>1.3.6.1.4.1.4491.2.2.7.4.1.3.2.5.1.3</oid>
    <status>current</status>
    <PKTC-ACLS:access-control>NetworkWritable</PKTC-ACLS:access-control>
    <user-hint>RW</user-hint>
  </xsd:appinfo>
  <xsd:documentation>
    Extension object for 'pktcRSTAncMapEntry'.
  </xsd:documentation>
</xsd:annotation>
</xsd:element>
<xsd:any namespace="##other" processContents="lax" minOccurs="0"
maxOccurs="unbounded"/>
</xsd:sequence>
<xsd:attribute name="pktcRSTAncRspCode" use="required">
  <xsd:annotation>
    <xsd:appinfo>
      <maxAccess>not-accessible</maxAccess>
      <oid>1.3.6.1.4.1.4491.2.2.7.4.1.3.2.5.1.1</oid>
      <status>current</status>
      <PKTC-ACLS:access-control>NetworkWritable</PKTC-ACLS:access-control>
      <user-hint>read-only</user-hint>
    </xsd:appinfo>
    <xsd:documentation>
      This data element specifies the Response code.
    </xsd:documentation>
  </xsd:annotation>
  <xsd:simpleType>
    <xsd:restriction base="smi:Integer32">
      <xsd:minInclusive value="0"/>
      <xsd:maxInclusive value="32000"/>
    </xsd:restriction>
  </xsd:simpleType>
</xsd:attribute>
</xsd:extension>
</xsd:complexContent>
</xsd:complexType>
<xsd:complexType name="pktcRSTAncMediaMapEntryType">
  <xsd:complexContent>
    <xsd:extension base="CL-PKTC-BASE-SVC:pktcPACMSvcFeature">
      <xsd:sequence>
        <xsd:element name="pktcRSTAncMediaURI" type="SNMP-FRAMEWORK-
MIB:SnmpAdminString">
          <xsd:annotation>
            <xsd:appinfo>
              <maxAccess>read-write</maxAccess>
              <oid>1.3.6.1.4.1.4491.2.2.7.4.1.3.2.6.1.2</oid>
              <status>current</status>
              <PKTC-ACLS:access-control>NetworkWritable</PKTC-ACLS:access-control>
              <user-hint>read-only</user-hint>
            </xsd:appinfo>
            <xsd:documentation>
              This data element specifies the Announcement Media Map entry.
              A string identifying the URI for announcement identifier.
            </xsd:documentation>
          </xsd:annotation>
        </xsd:element>
        <xsd:element name="eXTOBJpktcRSTAncMediaMapEntry" type="CL-PKTC-
TC:PkTcPACMExtension" minOccurs="0">
          <xsd:annotation>
            <xsd:appinfo>
              <maxAccess>read-only</maxAccess>
              <oid>1.3.6.1.4.1.4491.2.2.7.4.1.3.2.6.1.3</oid>
              <status>current</status>
              <PKTC-ACLS:access-control>NetworkWritable</PKTC-ACLS:access-control>
              <user-hint>RW</user-hint>
            </xsd:appinfo>

```



```

    <PKTC-ACLS:access-control>NetworkWritable</PKTC-ACLS:access-control>
    <user-hint>RW</user-hint>
  </xsd:appinfo>
  <xsd:documentation>
    Extension object for 'pktcRSTLocalMediaEntry'.
  </xsd:documentation>
  </xsd:annotation>
</xsd:element>
<xsd:any namespace="##other" processContents="lax" minOccurs="0"
maxOccurs="unbounded"/>
</xsd:sequence>
<xsd:attribute name="pktcRSTLocalMediaURI" type="SNMP-FRAMEWORK-
MIB:SnmpAdminString" use="required">
  <xsd:annotation>
    <xsd:appinfo>
      <maxAccess>not-accessible</maxAccess>
      <oid>1.3.6.1.4.1.4491.2.2.7.4.1.3.3.1.1.1</oid>
      <status>current</status>
      <PKTC-ACLS:access-control>NetworkWritable</PKTC-ACLS:access-control>
      <user-hint>read-only</user-hint>
    </xsd:appinfo>
    <xsd:documentation>
      This data element specifies the Local Media entry.
      A string identifying the URI for the Local Media.
    </xsd:documentation>
  </xsd:annotation>
</xsd:attribute>
</xsd:extension>
</xsd:complexContent>
</xsd:complexType>
<xsd:simpleType name="pktcRSTDigitMapPattern">
  <xsd:annotation>
    <xsd:documentation>
      A digit map pattern. Refer to the PacketCable RST
      Feature specification for detailed syntax and
      semantics.
    </xsd:documentation>
  </xsd:annotation>
  <xsd:restriction base="xsd:string"/>
</xsd:simpleType>
<xsd:simpleType name="pktcRSTDigitMapActionArg">
  <xsd:annotation>
    <xsd:documentation>
      A digit map action argument. Refer to the PacketCable RST
      Feature specification for detailed syntax and
      semantics.
    </xsd:documentation>
  </xsd:annotation>
  <xsd:restriction base="xsd:string"/>
</xsd:simpleType>
<xsd:element name="pktcRSTTimers">
  <xsd:annotation>
    <xsd:documentation>
      Short Interdigit Timer: Used when critical timing should be
      performed, such as when the dialed digits constitute a complete
      address, but additional digits may constitute a different
      complete address.
      For more info, refer to the PacketCable RST Feature specification
    </xsd:documentation>
  </xsd:annotation>
  <xsd:complexType>
    <xsd:attribute name="pktcRSTAttrT" type="xsd:decimal" use="optional">
      <xsd:annotation>
        <xsd:documentation>
          Start Timer: The length of time allowed to dial the first
          digit from the time dial tone is applied.
        </xsd:documentation>
      </xsd:annotation>
    </xsd:attribute>
  </xsd:complexType>
</xsd:element>

```

```
</xsd:annotation>
</xsd:attribute>
<xsd:attribute name="pktcRSTAttrS" type="xsd:decimal" use="optional"/>
<xsd:attribute name="pktcRSTAttrL" type="xsd:decimal" use="optional">
  <xsd:annotation>
    <xsd:documentation>
      Long Interdigit Timer: Long interdigit timer. The allowable time
      between digits if the short interdigit timer has not been
      indicated in the digitmap.
    </xsd:documentation>
  </xsd:annotation>
</xsd:attribute>
</xsd:complexType>
<xsd:attribute name="pktcRSTAttrZ" type="xsd:decimal" use="optional">
  <xsd:annotation>
    <xsd:documentation>
      Long Duration Timer: The duration a particular digit is to be
      held in order to be detected. When a Z is placed in a pattern,
      the Long Duration Timer is applied to the following key in the
      pattern.
    </xsd:documentation>
  </xsd:annotation>
</xsd:attribute>
</xsd:complexType>
</xsd:element>
<xsd:complexType name="pktcRSTActionType"/>
<xsd:element name="pktcRSTRule">
  <xsd:annotation>
    <xsd:documentation>
      A Digit map rule
    </xsd:documentation>
  </xsd:annotation>
  <xsd:complexType>
    <xsd:sequence>
      <xsd:element name="pktcRSTPattern" type="pktcRSTDigitMapPattern"/>
      <xsd:choice minOccurs="0" maxOccurs="unbounded">
        <xsd:element name="pktcRSTReturn" type="pktcRSTDigitMapActionArg"/>
        <xsd:element name="pktcRSTUseMap" type="pktcRSTDigitMapActionArg"/>
        <xsd:element name="pktcRSTCall" type="pktcRSTDigitMapActionArg"/>
        <xsd:element name="pktcRSTHold"/>
        <xsd:element name="pktcRSTRecall"/>
        <xsd:element name="pktcRSTReorder"/>
        <xsd:element name="pktcRSTAcrrActivate"/>
        <xsd:element name="pktcRSTAcrrDeactivate"/>
        <xsd:element name="pktcRSTAC"/>
        <xsd:element name="pktcRSTAR"/>
        <xsd:element name="pktcRSTCIDSsuppress"/>
        <xsd:element name="pktcRSTCIDDeliver"/>
        <xsd:element name="pktcRSTCOT"/>
        <xsd:element name="pktcRSTCWToggle"/>
        <xsd:element name="pktcRSTCFVProgram"/>
        <xsd:element name="pktcRSTDNDProgram"/>
        <xsd:element name="pktcRSTSCFProgram"/>
        <xsd:element name="pktcRSTSBMaint"/>
        <xsd:element name="pktcRSTSDProgram"/>
        <xsd:element name="pktcRSTSPProgram"/>
        <xsd:element name="pktcRSTEmergencyCall"/>
      </xsd:choice>
    </xsd:sequence>
  </xsd:complexType>
</xsd:element>
<xsd:element name="pktcRSTSymbolDef">
  <xsd:annotation>
    <xsd:documentation>
      A symbol or variable definition, for use in patterns or
      action arguments
    </xsd:documentation>
  </xsd:annotation>
</xsd:element>
```

```

<xsd:complexType>
  <xsd:simpleContent>
    <xsd:extension base="xsd:string">
      <xsd:attribute name="pktcRSTAttrName" type="xsd:string" use="required"/>
    </xsd:extension>
  </xsd:simpleContent>
</xsd:complexType>
</xsd:element>
<xsd:element name="pktcRSTMapDef">
  <xsd:annotation>
    <xsd:documentation>
      A digit map definition
    </xsd:documentation>
  </xsd:annotation>
  <xsd:complexType>
    <xsd:sequence>
      <xsd:element ref="pktcRSTRule" minOccurs="0" maxOccurs="unbounded"/>
    </xsd:sequence>
    <xsd:attribute name="pktcRSTAttrName" type="xsd:string" use="required"/>
  </xsd:complexType>
</xsd:element>
<xsd:complexType name="PktcRSTDIGITMAP">
  <xsd:sequence>
    <xsd:element ref="pktcRSTTimers"/>
    <xsd:element ref="pktcRSTSymbolDef" minOccurs="0" maxOccurs="unbounded"/>
    <xsd:element ref="pktcRSTMapDef" maxOccurs="unbounded"/>
  </xsd:sequence>
</xsd:complexType>
<xsd:complexType name="PktcRSTTONEANNC">
  <xsd:choice>
    <xsd:element name="tone" type="xsd:anyURI"/>
    <xsd:element name="announcement" type="xsd:string"/>
  </xsd:choice>
</xsd:complexType>
</xsd:schema>

```

## A.2 RST E-DVA Profile

```

<?xml version="1.0"?>
<!-- 2006 (c)CableLabs. All rights reserved -->
<!--PacketCable R2 PACM: XML Schema Definitions for "CL-PKTC-RST-EDVA" -->
<xsd:schema
  xmlns="http://www.cablelabs.com/namespaces/PacketCable/R2/XSD/smi/v1/CL-PKTC-
  RST-EDVA" xmlns:xsd="http://www.w3.org/2001/XMLSchema"
  xmlns:smi="http://www.cablelabs.com/namespaces/PacketCable/R2/XSD/smi/smi"
  xmlns:SNMPv2-
  SMI="http://www.cablelabs.com/namespaces/PacketCable/R2/XSD/smi/SNMPv2-SMI"
  xmlns:SNMPv2-
  CONF="http://www.cablelabs.com/namespaces/PacketCable/R2/XSD/smi/SNMPv2-CONF"
  xmlns:SNMPv2-
  TC="http://www.cablelabs.com/namespaces/PacketCable/R2/XSD/smi/SNMPv2-TC"
  xmlns:INET-ADDRESS-
  MIB="http://www.cablelabs.com/namespaces/PacketCable/R2/XSD/smi/INET-ADDRESS-
  MIB" xmlns:CL-PKTC-
  TC="http://www.cablelabs.com/namespaces/PacketCable/R2/XSD/v1/CL-PKTC-TC"
  xmlns:CLAB-DEF-
  MIB="http://www.cablelabs.com/namespaces/PacketCable/R2/XSD/smi/CLAB-DEF-MIB"
  xmlns:PKTC-ACLS="http://www.cablelabs.com/namespaces/PacketCable/R2/XSD/v1/CL-
  PKTC-ACLS"
  targetNamespace="http://www.cablelabs.com/namespaces/PacketCable/R2/XSD/smi/v1/C
  L-PKTC-RST-EDVA" elementFormDefault="qualified"
  attributeFormDefault="unqualified" xml:lang="en">
  <xsd:annotation>
    <xsd:documentation>
      This XML Schema contains configuration MIB
      objects for the RST Service Embedded Digital

```

```
    Voice Adaptor (E-DVA). The objects are referenced
    in the PacketCable Residential SIP Telephony (RST)
    E-DVA specification.
  </xsd:documentation>
</xsd:annotation>
<xsd:import
namespace="http://www.cablelabs.com/namespaces/PacketCable/R2/XSD/smi/smi"
schemaLocation="http://www.cablelabs.com/namespaces/PacketCable/R2/XSD/smi/SMI.xsd"/>
  <xsd:import
namespace="http://www.cablelabs.com/namespaces/PacketCable/R2/XSD/smi/SNMPv2-SMI"
schemaLocation="http://www.cablelabs.com/namespaces/PacketCable/R2/XSD/smi/SNMPv2-SMI.xsd"/>
  <xsd:import
namespace="http://www.cablelabs.com/namespaces/PacketCable/R2/XSD/smi/SNMPv2-CONF"
schemaLocation="http://www.cablelabs.com/namespaces/PacketCable/R2/XSD/smi/SNMPv2-CONF.xsd"/>
  <xsd:import
namespace="http://www.cablelabs.com/namespaces/PacketCable/R2/XSD/smi/SNMPv2-TC"
schemaLocation="http://www.cablelabs.com/namespaces/PacketCable/R2/XSD/smi/SNMPv2-TC.xsd"/>
  <xsd:import
namespace="http://www.cablelabs.com/namespaces/PacketCable/R2/XSD/smi/INET-ADDRESS-MIB"
schemaLocation="http://www.cablelabs.com/namespaces/PacketCable/R2/XSD/smi/INET-ADDRESS-MIB.xsd"/>
  <xsd:import
namespace="http://www.cablelabs.com/namespaces/PacketCable/R2/XSD/v1/CL-PKTC-TC"
schemaLocation="http://www.cablelabs.com/namespaces/PacketCable/R2/XSD/v1/CL-PKTC-TC.xsd"/>
  <xsd:import
namespace="http://www.cablelabs.com/namespaces/PacketCable/R2/XSD/smi/CLAB-DEF-MIB"
schemaLocation="http://www.cablelabs.com/namespaces/PacketCable/R2/XSD/smi/CLAB-DEF-MIB.xsd"/>
  <xsd:import
namespace="http://www.cablelabs.com/namespaces/PacketCable/R2/XSD/v1/CL-PKTC-ACL"
schemaLocation="http://www.cablelabs.com/namespaces/PacketCable/R2/XSD/v1/CL-PKTC-ACL.xsd"/>
  <xsd:element name="CL-PKTC-RST-EDVA">
    <xsd:annotation>
      <xsd:appinfo>
        <PKTC-ACLS:access-control>NetworkWritable</PKTC-ACLS:access-control>
      </xsd:appinfo>
    </xsd:annotation>
    <xsd:complexType>
      <xsd:sequence>
        <xsd:element ref="PKTC-ACLS:aggregated-acls" minOccurs="0"/>
        <xsd:element name="pktcPACMRSTEDVAObjects"
type="pktcPACMRSTEDVAObjectsType">
          <xsd:annotation>
            <xsd:appinfo>
              <maxAccess>unknown</maxAccess>
              <oid>1.3.6.1.4.1.4491.2.2.7.5.1</oid>
              <status>unknown</status>
            </xsd:appinfo>
          </xsd:annotation>
        </xsd:element>
        <xsd:element name="pktcPACMRSTEDVAProfileIDs"
type="pktcPACMRSTEDVAProfileIDsType" minOccurs="0">
          <xsd:annotation>
            <xsd:appinfo>
              <maxAccess>unknown</maxAccess>
              <oid>1.3.6.1.4.1.4491.2.2.7.5.1.2</oid>
```

```

        <status>unknown</status>
      </xsd:appinfo>
    </xsd:annotation>
  </xsd:element>
  <xsd:element name="pktrSTEDVANetDiscProfile"
type="pktrSTEDVANetDiscProfileType" minOccurs="0">
    <xsd:annotation>
      <xsd:appinfo>
        <maxAccess>unknown</maxAccess>
        <oid>1.3.6.1.4.1.4491.2.2.7.5.1.3.1</oid>
        <status>unknown</status>
      </xsd:appinfo>
    </xsd:annotation>
  </xsd:element>
  <xsd:element name="pktrSTEDVAAnsSupProfile"
type="pktrSTEDVAAnsSupProfileType" minOccurs="0">
    <xsd:annotation>
      <xsd:appinfo>
        <maxAccess>unknown</maxAccess>
        <oid>1.3.6.1.4.1.4491.2.2.7.5.1.3.2</oid>
        <status>unknown</status>
      </xsd:appinfo>
    </xsd:annotation>
  </xsd:element>
  <xsd:element name="pktrSTEDVADtmfProfile" type="pktrSTEDVADtmfProfileType"
minOccurs="0">
    <xsd:annotation>
      <xsd:appinfo>
        <maxAccess>unknown</maxAccess>
        <oid>1.3.6.1.4.1.4491.2.2.7.5.1.3.3</oid>
        <status>unknown</status>
      </xsd:appinfo>
    </xsd:annotation>
  </xsd:element>
  <xsd:element name="pktrSTEDVAPrLossProfile"
type="pktrSTEDVAPrLossProfileType" minOccurs="0">
    <xsd:annotation>
      <xsd:appinfo>
        <maxAccess>unknown</maxAccess>
        <oid>1.3.6.1.4.1.4491.2.2.7.5.1.3.4</oid>
        <status>unknown</status>
      </xsd:appinfo>
    </xsd:annotation>
  </xsd:element>
  <xsd:element name="pktrSTEDVADCBiasProfile"
type="pktrSTEDVADCBiasProfileType" minOccurs="0">
    <xsd:annotation>
      <xsd:appinfo>
        <maxAccess>unknown</maxAccess>
        <oid>1.3.6.1.4.1.4491.2.2.7.5.1.3.5</oid>
        <status>unknown</status>
      </xsd:appinfo>
    </xsd:annotation>
  </xsd:element>
  <xsd:element name="pktrSTEDVAMWISignalTypes"
type="pktrSTEDVAMWISignalTypesType" minOccurs="0">
    <xsd:annotation>
      <xsd:appinfo>
        <maxAccess>unknown</maxAccess>
        <oid>1.3.6.1.4.1.4491.2.2.7.5.1.3.6</oid>
        <status>unknown</status>
      </xsd:appinfo>
    </xsd:annotation>
  </xsd:element>
  <xsd:element name="pktrSTEDVACodecProfile"
type="pktrSTEDVACodecProfileType" minOccurs="0">
    <xsd:annotation>

```

```

        <xsd:appinfo>
        <maxAccess>unknown</maxAccess>
        <oid>1.3.6.1.4.1.4491.2.2.7.5.1.3.7</oid>
        <status>unknown</status>
        </xsd:appinfo>
    </xsd:annotation>
</xsd:element>
<xsd:element name="pktcRSTEDVATimeProfile" type="pktcRSTEDVATimeProfileType"
minOccurs="0">
    <xsd:annotation>
        <xsd:appinfo>
            <maxAccess>unknown</maxAccess>
            <oid>1.3.6.1.4.1.4491.2.2.7.5.1.3.8</oid>
            <status>unknown</status>
        </xsd:appinfo>
    </xsd:annotation>
</xsd:element>
<xsd:element name="pktcRSTEDVANetDiscTableEntry"
type="pktcRSTEDVANetDiscTableEntryType" minOccurs="0" maxOccurs="unbounded">
    <xsd:annotation>
        <xsd:appinfo>
            <maxAccess>not-accessible</maxAccess>
            <oid>1.3.6.1.4.1.4491.2.2.7.5.1.3.1.1.1</oid>
            <status>current</status>
            <PKTC-ACLS:access-control>NetworkWritable</PKTC-ACLS:access-control>
            <user-hint>read-only</user-hint>
        </xsd:appinfo>
        <xsd:documentation>
            Each entry in this data table describes the Network
Disconnect
            Time for the associated line.
        </xsd:documentation>
    </xsd:annotation>
</xsd:element>
<xsd:element name="pktcRSTEDVAAnsSupTableEntry"
type="pktcRSTEDVAAnsSupTableEntryType" maxOccurs="unbounded">
    <xsd:annotation>
        <xsd:appinfo>
            <maxAccess>not-accessible</maxAccess>
            <oid>1.3.6.1.4.1.4491.2.2.7.5.1.3.2.1.1</oid>
            <status>current</status>
            <PKTC-ACLS:access-control>NetworkWritable</PKTC-ACLS:access-control>
            <user-hint>read-only</user-hint>
        </xsd:appinfo>
        <xsd:documentation>
            Each entry in this data table describes the Answer
Supervision
            for the associated line.
        </xsd:documentation>
    </xsd:annotation>
</xsd:element>
<xsd:element name="pktcRSTEDVAPrLossTableEntry"
type="pktcRSTEDVAPrLossTableEntryType" maxOccurs="unbounded">
    <xsd:annotation>
        <xsd:appinfo>
            <maxAccess>not-accessible</maxAccess>
            <oid>1.3.6.1.4.1.4491.2.2.7.5.1.3.4.1.1</oid>
            <status>current</status>
            <PKTC-ACLS:access-control>NetworkWritable</PKTC-ACLS:access-control>
            <user-hint>read-only</user-hint>
        </xsd:appinfo>
        <xsd:documentation>
            The DVA supports two provisioned loss parameters, one for
            the D/A direction (towards the subscriber) and one for A/D
            direction (from the subscriber) direction. This data table
            represents the loss for each line provided by the E-DVA.
    </xsd:documentation>
    </xsd:annotation>
</xsd:element>

```

```

        Each entry in this data table describes the loss
        for the associated line.
    </xsd:documentation>
</xsd:annotation>
</xsd:element>
<xsd:element name="pktcRSTEDVADCBiasTableEntry"
type="pktcRSTEDVADCBiasTableEntryType" maxOccurs="unbounded">
    <xsd:annotation>
        <xsd:appinfo>
            <maxAccess>not-accessible</maxAccess>
            <oid>1.3.6.1.4.1.4491.2.2.7.5.1.3.5.1.1</oid>
            <status>current</status>
            <PKTC-ACLS:access-control>NetworkWritable</PKTC-ACLS:access-control>
            <user-hint>read-only</user-hint>
        </xsd:appinfo>
        <xsd:documentation>
            DCbias is the signaling method to indicate the Network/E-DVA
            in/out of service state. The Operator is able to provision
to
            enable planned, scheduled service times to not be signaled
as
            an out of service state pending a maximum duration element.
            This data table represents the On Hook In/Out of Service
parameters
            each line provided by the E-DVA.

            Each entry in this data table describes the On Hook
            In/Out of Service parameters for the associated line.
        </xsd:documentation>
    </xsd:annotation>
</xsd:element>
</xsd:sequence>
</xsd:complexType>
</xsd:element>
<xsd:complexType name="pktcPACMRSTEDVAObjectsType">
    <xsd:sequence>
        <xsd:element name="pktcPACMRSTEDVAMinorVersion" type="smi:Integer32"
default="0">
            <xsd:annotation>
                <xsd:appinfo>
                    <maxAccess>read-only</maxAccess>
                    <oid>1.3.6.1.4.1.4491.2.2.7.5.1.1</oid>
                    <status>current</status>
                    <default>0</default>
                    <PKTC-ACLS:access-control>NetworkWritable</PKTC-ACLS:access-control>
                    <user-hint>R0</user-hint>
                </xsd:appinfo>
                <xsd:documentation>
                    The default value of this MIB Object contains the minor version
                    of the data model.
                </xsd:documentation>
            </xsd:annotation>
        </xsd:element>
        <xsd:element name="eXTOBJpktcPACMRSTEDVAObjects" type="CL-PKTC-
TC:PktcPACMExtension" minOccurs="0">
            <xsd:annotation>
                <xsd:appinfo>
                    <maxAccess>read-only</maxAccess>
                    <oid>1.3.6.1.4.1.4491.2.2.7.5.1.4</oid>
                    <status>current</status>
                    <PKTC-ACLS:access-control>NetworkWritable</PKTC-ACLS:access-control>
                    <user-hint>RW</user-hint>
                </xsd:appinfo>
                <xsd:documentation>
                    Extension object for 'pktcPACMRSTEDVAObjects'.
                </xsd:documentation>
            </xsd:annotation>
        </xsd:element>
    </xsd:sequence>
</xsd:complexType>

```

```

        </xsd:element>
        <xsd:any namespace="##other" processContents="lax" minOccurs="0"
maxOccurs="unbounded" />
    </xsd:sequence>
</xsd:complexType>
<xsd:complexType name="pktcPACMRSTEDVAProfileIDsType">
    <xsd:sequence>
        <xsd:element name="eXTOBJpktcPACMRSTEDVAProfileIDs" type="CL-PKTC-
TC:PktcPACMExtension" minOccurs="0">
            <xsd:annotation>
                <xsd:appinfo>
                    <maxAccess>read-only</maxAccess>
                    <oid>1.3.6.1.4.1.4491.2.2.7.5.1.2.2</oid>
                    <status>current</status>
                    <PKTC-ACLS:access-control>NetworkWritable</PKTC-ACLS:access-control>
                    <user-hint>RW</user-hint>
                </xsd:appinfo>
                <xsd:documentation>
                    Extension object for 'pktcPACMRSTEDVAProfileIDs'.
                </xsd:documentation>
            </xsd:annotation>
        </xsd:element>
        <xsd:any namespace="##other" processContents="lax" minOccurs="0"
maxOccurs="unbounded" />
    </xsd:sequence>
</xsd:complexType>
<xsd:complexType name="pktcRSTEDVANetDiscProfileType">
    <xsd:sequence>
        <xsd:element name="eXTOBJpktcRSTEDVANetDiscProfile" type="CL-PKTC-
TC:PktcPACMExtension" minOccurs="0">
            <xsd:annotation>
                <xsd:appinfo>
                    <maxAccess>read-only</maxAccess>
                    <oid>1.3.6.1.4.1.4491.2.2.7.5.1.3.1.2</oid>
                    <status>current</status>
                    <PKTC-ACLS:access-control>NetworkWritable</PKTC-ACLS:access-control>
                    <user-hint>RW</user-hint>
                </xsd:appinfo>
                <xsd:documentation>
                    Extension object for 'pktcRSTEDVANetDiscProfile'.
                </xsd:documentation>
            </xsd:annotation>
        </xsd:element>
        <xsd:any namespace="##other" processContents="lax" minOccurs="0"
maxOccurs="unbounded" />
    </xsd:sequence>
</xsd:complexType>
<xsd:complexType name="pktcRSTEDVAAnsSupProfileType">
    <xsd:sequence>
        <xsd:element name="eXTOBJpktcRSTEDVAAnsSupProfile" type="CL-PKTC-
TC:PktcPACMExtension" minOccurs="0">
            <xsd:annotation>
                <xsd:appinfo>
                    <maxAccess>read-only</maxAccess>
                    <oid>1.3.6.1.4.1.4491.2.2.7.5.1.3.2.2</oid>
                    <status>current</status>
                    <PKTC-ACLS:access-control>NetworkWritable</PKTC-ACLS:access-control>
                    <user-hint>RW</user-hint>
                </xsd:appinfo>
                <xsd:documentation>
                    Extension object for 'pktcRSTEDVAAnsSupProfile'.
                </xsd:documentation>
            </xsd:annotation>
        </xsd:element>
        <xsd:any namespace="##other" processContents="lax" minOccurs="0"
maxOccurs="unbounded" />
    </xsd:sequence>

```

```

</xsd:complexType>
<xsd:complexType name="pktcRSTEDVADtmfProfileType">
  <xsd:sequence>
    <xsd:element name="pktcRSTEDVADtmfRelay" type="SNMPv2-TC:TruthValue"
default="true">
      <xsd:annotation>
        <xsd:appinfo>
          <maxAccess>read-write</maxAccess>
          <oid>1.3.6.1.4.1.4491.2.2.7.5.1.3.3.1</oid>
          <status>current</status>
          <default>true</default>
          <PKTC-ACLS:access-control>NetworkWritable</PKTC-ACLS:access-control>
          <user-hint>read-only</user-hint>
        </xsd:appinfo>
        <xsd:documentation>
          This data table represents the DTMF Relay status
          for each line provided by the E-DVA.
          The E-DVA must support the use of DTMF for both dialed digits
          and for the relay of digits as part of an established session.
          When dialing the DTMF, signaling MUST be collected at the E-DVA.
          The digits are gathered according to the digit map and all digits
          are sent in a single message.

          If the value of this object is 'true' (on), the E-DVA must offer
          DTMF relay within SDP upon session origination.

          The E-DVA MUST implement this element per the PacketCable
          Residential SIP Telephony E-DVA Specification.
        </xsd:documentation>
      </xsd:annotation>
    </xsd:element>
    <xsd:element name="eXTOBJpktcRSTEDVADtmfProfile" type="CL-PKTC-
TC:PkTcPACMExtension" minOccurs="0">
      <xsd:annotation>
        <xsd:appinfo>
          <maxAccess>read-only</maxAccess>
          <oid>1.3.6.1.4.1.4491.2.2.7.5.1.3.3.3</oid>
          <status>current</status>
          <PKTC-ACLS:access-control>NetworkWritable</PKTC-ACLS:access-control>
          <user-hint>RW</user-hint>
        </xsd:appinfo>
        <xsd:documentation>
          Extension object for 'pktcRSTEDVADtmfProfile'.
        </xsd:documentation>
      </xsd:annotation>
    </xsd:element>
    <xsd:any namespace="##other" processContents="lax" minOccurs="0"
maxOccurs="unbounded"/>
  </xsd:sequence>
</xsd:complexType>
<xsd:complexType name="pktcRSTEDVAPrLossProfileType">
  <xsd:sequence>
    <xsd:element name="eXTOBJpktcRSTEDVAPrLossProfile" type="CL-PKTC-
TC:PkTcPACMExtension" minOccurs="0">
      <xsd:annotation>
        <xsd:appinfo>
          <maxAccess>read-only</maxAccess>
          <oid>1.3.6.1.4.1.4491.2.2.7.5.1.3.4.2</oid>
          <status>current</status>
          <PKTC-ACLS:access-control>NetworkWritable</PKTC-ACLS:access-control>
          <user-hint>RW</user-hint>
        </xsd:appinfo>
        <xsd:documentation>
          Extension object for 'pktcPACMRSTEDVAObjects'.
        </xsd:documentation>
      </xsd:annotation>
    </xsd:element>
  </xsd:sequence>
</xsd:complexType>

```

```

        </xsd:element>
        <xsd:any namespace="##other" processContents="lax" minOccurs="0"
maxOccurs="unbounded" />
    </xsd:sequence>
</xsd:complexType>
<xsd:complexType name="pktcRSTEDVADCBiasProfileType">
    <xsd:sequence>
        <xsd:element name="eXTOBJpktcRSTEDVADCBiasProfile" type="CL-PKTC-
TC:PktcPACMExtension" minOccurs="0">
            <xsd:annotation>
                <xsd:appinfo>
                    <maxAccess>read-only</maxAccess>
                    <oid>1.3.6.1.4.1.4491.2.2.7.5.1.3.5.2</oid>
                    <status>current</status>
                    <PKTC-ACLS:access-control>NetworkWritable</PKTC-ACLS:access-control>
                    <user-hint>RW</user-hint>
                </xsd:appinfo>
                <xsd:documentation>
                    Extension object for 'pktcRSTEDVADCBiasProfile'.
                </xsd:documentation>
            </xsd:annotation>
        </xsd:element>
        <xsd:any namespace="##other" processContents="lax" minOccurs="0"
maxOccurs="unbounded" />
    </xsd:sequence>
</xsd:complexType>
<xsd:complexType name="pktcRSTEDVAMWISignalTypesType">
    <xsd:sequence>
        <xsd:element name="pktcRSTEDVAMWIToneInd" type="SNMPv2-TC:TruthValue">
            <xsd:annotation>
                <xsd:appinfo>
                    <maxAccess>read-write</maxAccess>
                    <oid>1.3.6.1.4.1.4491.2.2.7.5.1.3.6.1</oid>
                    <status>current</status>
                    <PKTC-ACLS:access-control>NetworkWritable</PKTC-ACLS:access-control>
                    <user-hint>read-only</user-hint>
                </xsd:appinfo>
                <xsd:documentation>
                    This is the MWI Tone Indicator.

                    The E-DVA MUST implement this element per the PacketCable
Residential SIP Telephony E-DVA Specification.
                </xsd:documentation>
            </xsd:annotation>
        </xsd:element>
        <xsd:element name="pktcRSTEDVAMWIAncInd" type="SNMPv2-TC:TruthValue">
            <xsd:annotation>
                <xsd:appinfo>
                    <maxAccess>read-write</maxAccess>
                    <oid>1.3.6.1.4.1.4491.2.2.7.5.1.3.6.2</oid>
                    <status>current</status>
                    <PKTC-ACLS:access-control>NetworkWritable</PKTC-ACLS:access-control>
                    <user-hint>read-only</user-hint>
                </xsd:appinfo>
                <xsd:documentation>
                    This is the MWI Voice Announcement Indication.

                    The E-DVA MUST implement this element per the PacketCable
Residential SIP Telephony E-DVA Specification.
                </xsd:documentation>
            </xsd:annotation>
        </xsd:element>
        <xsd:element name="pktcRSTEDVAMWIFSKInd" type="SNMPv2-TC:TruthValue">
            <xsd:annotation>
                <xsd:appinfo>
    
```

```

<maxAccess>read-write</maxAccess>
<oid>1.3.6.1.4.1.4491.2.2.7.5.1.3.6.3</oid>
<status>current</status>
<PKTC-ACLS:access-control>NetworkWritable</PKTC-ACLS:access-control>
<user-hint>read-only</user-hint>
</xsd:appinfo>
<xsd:documentation>
  This is the MWI FSK Indication.

```

The E-DVA MUST implement this element per the PacketCable Residential

```

  SIP Telephony E-DVA Specification.
  </xsd:documentation>
</xsd:annotation>
</xsd:element>
<xsd:element name="pktcRSTEDVAMWIDTMFInd" type="SNMPv2-TC:TruthValue">
  <xsd:annotation>
    <xsd:appinfo>
      <maxAccess>read-write</maxAccess>
      <oid>1.3.6.1.4.1.4491.2.2.7.5.1.3.6.4</oid>
      <status>current</status>
      <PKTC-ACLS:access-control>NetworkWritable</PKTC-ACLS:access-control>
      <user-hint>read-only</user-hint>
    </xsd:appinfo>
    <xsd:documentation>
      This is the MWI DTMF Indication.

```

The E-DVA MUST implement this element per the PacketCable Residential

```

  SIP Telephony E-DVA Specification.
  </xsd:documentation>
</xsd:annotation>
</xsd:element>
<xsd:element name="eXTObjpktcRSTEDVAMWISignalTypes" type="CL-PKTC-
TC:PkTcPACMExtension" minOccurs="0">
  <xsd:annotation>
    <xsd:appinfo>
      <maxAccess>read-only</maxAccess>
      <oid>1.3.6.1.4.1.4491.2.2.7.5.1.3.6.5</oid>
      <status>current</status>
      <PKTC-ACLS:access-control>NetworkWritable</PKTC-ACLS:access-control>
      <user-hint>RW</user-hint>
    </xsd:appinfo>
    <xsd:documentation>
      Extension object for 'pktcRSTEDVAMWISignalTypes'.
    </xsd:documentation>
  </xsd:annotation>
</xsd:element>
<xsd:any namespace="##other" processContents="lax" minOccurs="0"
maxOccurs="unbounded"/>
</xsd:sequence>
</xsd:complexType>
<xsd:complexType name="pktcRSTEDVACodecProfileType">
  <xsd:sequence>
    <xsd:element name="pktcRSTEDVACodecG711Pkt" minOccurs="0" default="20">
      <xsd:annotation>
        <xsd:appinfo>
          <maxAccess>read-write</maxAccess>
          <oid>1.3.6.1.4.1.4491.2.2.7.5.1.3.7.1</oid>
          <status>current</status>
          <default>20</default>
          <PKTC-ACLS:access-control>NetworkWritable</PKTC-ACLS:access-control>
          <user-hint>read-only</user-hint>
        </xsd:appinfo>
        <xsd:documentation>
          This data element specifies the packetization period of a
          G.711 payload.

```

The E-DVA MUST implement this element per the PacketCable  
 Residential

```

    SIP Telephony E-DVA Specification.
    </xsd:documentation>
  </xsd:annotation>
  <xsd:simpleType>
    <xsd:union>
      <xsd:simpleType>
        <xsd:restriction base="smi:Integer32">
          <xsd:minInclusive value="10"/>
          <xsd:maxInclusive value="10"/>
        </xsd:restriction>
      </xsd:simpleType>
      <xsd:simpleType>
        <xsd:restriction base="smi:Integer32">
          <xsd:minInclusive value="20"/>
          <xsd:maxInclusive value="20"/>
        </xsd:restriction>
      </xsd:simpleType>
      <xsd:simpleType>
        <xsd:restriction base="smi:Integer32">
          <xsd:minInclusive value="30"/>
          <xsd:maxInclusive value="30"/>
        </xsd:restriction>
      </xsd:simpleType>
    </xsd:union>
  </xsd:simpleType>
  </xsd:element>
  <xsd:element name="pktcRSTEDVACodecT38" type="SNMPv2-TC:TruthValue"
  default="true">
    <xsd:annotation>
      <xsd:appinfo>
        <maxAccess>read-write</maxAccess>
        <oid>1.3.6.1.4.1.4491.2.2.7.5.1.3.7.2</oid>
        <status>current</status>
        <default>true</default>
        <PKTC-ACLS:access-control>NetworkWritable</PKTC-ACLS:access-control>
        <user-hint>read-only</user-hint>
      </xsd:appinfo>
      <xsd:documentation>
        This data element specifies whether fax relay is enabled/disabled.
        A value of 'true' (ON) enables fax relay on the E-DVA.
      </xsd:documentation>
    </xsd:annotation>
  </xsd:element>

```

The E-DVA MUST implement this element per the PacketCable  
 Residential

```

    SIP Telephony E-DVA Specification.
    </xsd:documentation>
  </xsd:annotation>
  </xsd:element>
  <xsd:element name="pktcRSTEDVACodecV152" type="SNMPv2-TC:TruthValue"
  default="true">
    <xsd:annotation>
      <xsd:appinfo>
        <maxAccess>read-write</maxAccess>
        <oid>1.3.6.1.4.1.4491.2.2.7.5.1.3.7.3</oid>
        <status>current</status>
        <default>true</default>
        <PKTC-ACLS:access-control>NetworkWritable</PKTC-ACLS:access-control>
        <user-hint>read-only</user-hint>
      </xsd:appinfo>
      <xsd:documentation>
        This data element specifies whether modem relay is enabled/disable.
        A value of 'true' (ON) enables modem relay on the E-DVA.
      </xsd:documentation>
    </xsd:annotation>
  </xsd:element>

```

The E-DVA MUST implement this element per the PacketCable  
 Residential

SIP Telephony E-DVA Specification.

```

        </xsd:documentation>
    </xsd:annotation>
</xsd:element>
<xsd:element name="pktcRSTEDVACodecPubRepAddrType" type="INET-ADDRESS-
MIB:InetAddressType">
    <xsd:annotation>
        <xsd:appinfo>
            <maxAccess>read-write</maxAccess>
            <oid>1.3.6.1.4.1.4491.2.2.7.5.1.3.7.4</oid>
            <status>current</status>
            <PKTC-ACLS:access-control>NetworkWritable</PKTC-ACLS:access-control>
            <user-hint>read-only</user-hint>
        </xsd:appinfo>
        <xsd:documentation>
            This data element specifies the domain for the address
            specified in pktcRSTEDVACodecPubRepAddr. If the element
            pktcRSTEDVACodecPubRepAddr contains a valid IP address,
            this element MUST be either 'ipv4(1)' or 'ipv6(2)' per
            RFC3291.
        </xsd:documentation>
    </xsd:annotation>
</xsd:element>
<xsd:element name="pktcRSTEDVACodecPubRepAddr" type="INET-ADDRESS-
MIB:InetAddress">
    <xsd:annotation>
        <xsd:appinfo>
            <maxAccess>read-write</maxAccess>
            <oid>1.3.6.1.4.1.4491.2.2.7.5.1.3.7.5</oid>
            <status>current</status>
            <PKTC-ACLS:access-control>NetworkWritable</PKTC-ACLS:access-control>
            <user-hint>read-only</user-hint>
        </xsd:appinfo>
        <xsd:documentation>
            This data element specifies the network address that receives
            the call statistics report from the E-DVA. Publish reports must
            be sent at the end of each call if enabled.

            This address is associated with the domain specified in
            pktcRSTEDVACodecPubRepAddrType.

            The E-DVA MUST implement this element per the PacketCable
            Residential SIP Telephony E-DVA Specification.
        </xsd:documentation>
    </xsd:annotation>
</xsd:element>
<xsd:element name="pktcRSTEDVACodecRTCPXR" type="SNMPv2-TC:TruthValue"
default="true">
    <xsd:annotation>
        <xsd:appinfo>
            <maxAccess>read-write</maxAccess>
            <oid>1.3.6.1.4.1.4491.2.2.7.5.1.3.7.6</oid>
            <status>current</status>
            <default>true</default>
            <PKTC-ACLS:access-control>NetworkWritable</PKTC-ACLS:access-control>
            <user-hint>read-only</user-hint>
        </xsd:appinfo>
        <xsd:documentation>
            This data element specifies if extended reports for the sake of
            voice metrics are included within RTCP packets. A value of 'true' (ON)
            enables RTCP extended reports.

            The E-DVA MUST implement this element per the PacketCable
            Residential SIP Telephony E-DVA Specification.
        </xsd:documentation>

```

```

    </xsd:annotation>
  </xsd:element>
  <xsd:element name="pktcRSTEDVACodecRTCPRate" default="5">
    <xsd:annotation>
      <xsd:appinfo>
        <maxAccess>read-write</maxAccess>
        <oid>1.3.6.1.4.1.4491.2.2.7.5.1.3.7.7</oid>
        <status>current</status>
        <default>5</default>
        <PKTC-ACLS:access-control>NetworkWritable</PKTC-ACLS:access-control>
        <user-hint>read-only</user-hint>
      </xsd:appinfo>
      <xsd:documentation>
        This data element specifies the interval at which RTCP packets are
        sent from the E-DVA. A value of zero for RTCP_RATE disables RTCP
        transmission.

        The E-DVA MUST implement this element per the PacketCable
        Residential SIP Telephony E-DVA Specification.
      </xsd:documentation>
    </xsd:annotation>
    <xsd:simpleType>
      <xsd:restriction base="smi:Integer32">
        <xsd:minInclusive value="0"/>
        <xsd:maxInclusive value="60"/>
      </xsd:restriction>
    </xsd:simpleType>
  </xsd:element>
  <xsd:element name="eXTOBJpktcRSTEDVACodecProfile" type="CL-PKTC-
  TC:PktpcPACMExtension" minOccurs="0">
    <xsd:annotation>
      <xsd:appinfo>
        <maxAccess>read-only</maxAccess>
        <oid>1.3.6.1.4.1.4491.2.2.7.5.1.3.7.8</oid>
        <status>current</status>
        <PKTC-ACLS:access-control>NetworkWritable</PKTC-ACLS:access-control>
        <user-hint>RW</user-hint>
      </xsd:appinfo>
      <xsd:documentation>
        Extension object for 'pktcRSTEDVACodecProfile'.
      </xsd:documentation>
    </xsd:annotation>
  </xsd:element>
  <xsd:any namespace="##other" processContents="lax" minOccurs="0"
  maxOccurs="unbounded"/>
</xsd:sequence>
</xsd:complexType>
<xsd:complexType name="pktcRSTEDVATimeProfileType">
  <xsd:sequence>
    <xsd:element name="pktcRSTEDVATimeSync" minOccurs="0" default="48">
      <xsd:annotation>
        <xsd:appinfo>
          <maxAccess>read-write</maxAccess>
          <oid>1.3.6.1.4.1.4491.2.2.7.5.1.3.8.1</oid>
          <status>current</status>
          <default>48</default>
          <PKTC-ACLS:access-control>NetworkWritable</PKTC-ACLS:access-control>
          <user-hint>read-only</user-hint>
        </xsd:appinfo>
        <xsd:documentation>
          This data element specifies time synchronization interval.
          A PacketCable E-DVA must support a provisionable network time
          synchronization interval. The time synchronization interval range
          must be from 0 to 4320 hours (180 days) in increments of 1 hour.
          A provisioned value of '0' indicates the E-DVA must NOT execute
          network time resynchronization. The default network time
        </xsd:documentation>
      </xsd:annotation>
    </xsd:element>
  </xsd:sequence>
</xsd:complexType>

```

synchronization interface is 48 hours.

The E-DVA MUST implement this element per the PacketCable Residential

SIP Telephony E-DVA Specification.

```

</xsd:documentation>
</xsd:annotation>
<xsd:simpleType>
  <xsd:restriction base="smi:Integer32">
    <xsd:minInclusive value="0"/>
    <xsd:maxInclusive value="4320"/>
  </xsd:restriction>
</xsd:simpleType>
</xsd:element>
<xsd:element name="eXTOBJpktcRSTEDVATimeProfile" type="CL-PKTC-
TC:PktcPACMExtension" minOccurs="0">
  <xsd:annotation>
    <xsd:appinfo>
      <maxAccess>read-only</maxAccess>
      <oid>1.3.6.1.4.1.4491.2.2.7.5.1.3.8.2</oid>
      <status>current</status>
      <PKTC-ACLS:access-control>NetworkWritable</PKTC-ACLS:access-control>
      <user-hint>RW</user-hint>
    </xsd:appinfo>
    <xsd:documentation>
      Extension object for 'pktcRSTEDVATimeProfile'.
    </xsd:documentation>
  </xsd:annotation>
</xsd:element>
<xsd:any namespace="##other" processContents="lax" minOccurs="0"
maxOccurs="unbounded"/>
</xsd:sequence>
</xsd:complexType>
<xsd:complexType name="pktcRSTEDVANetDiscTableEntryType">
  <xsd:sequence>
    <xsd:element name="pktcRSTEDVANetDisc" minOccurs="0" default="1000">
      <xsd:annotation>
        <xsd:appinfo>
          <maxAccess>read-write</maxAccess>
          <oid>1.3.6.1.4.1.4491.2.2.7.5.1.3.1.1.1.1</oid>
          <status>current</status>
          <default>1000</default>
          <PKTC-ACLS:access-control>NetworkWritable</PKTC-ACLS:access-control>
          <user-hint>read-only</user-hint>
        </xsd:appinfo>
        <xsd:documentation>
          This data element specifies the time in mSec that the E-DVA
          must remove DC bias when a call has been cleared by the network.

          A value of zero (0) indicates that the E-DVA MUST NOT remove DC bias
          when a call disconnects. The E-DVA MUST implement this element per
          PKT-SP-RST-E-DVA Section 7.2.3
        </xsd:documentation>
      </xsd:annotation>
    </xsd:element>
  </xsd:sequence>
</xsd:complexType>
<xsd:element name="eXTOBJpktcRSTEDVANetDiscTableEntry" type="CL-PKTC-
TC:PktcPACMExtension" minOccurs="0">
  <xsd:annotation>
    <xsd:appinfo>
      <maxAccess>read-only</maxAccess>
      <oid>1.3.6.1.4.1.4491.2.2.7.5.1.3.1.1.1.2</oid>
    </xsd:appinfo>
  </xsd:annotation>

```

```
<status>current</status>
<PKTC-ACLS:access-control>NetworkWritable</PKTC-ACLS:access-control>
<user-hint>RW</user-hint>
</xsd:appinfo>
<xsd:documentation>
  Extension object for 'pktcRSTEDVANetDiscTableEntry'.
</xsd:documentation>
</xsd:annotation>
</xsd:element>
<xsd:any namespace="##other" processContents="lax" minOccurs="0"
maxOccurs="unbounded"/>
</xsd:sequence>
<xsd:attribute name="pktcRSTEDVALineNumber" use="required">
<xsd:annotation>
<xsd:appinfo>
  <maxAccess>not-accessible</maxAccess>
  <oid>1.3.6.1.4.1.4491.2.2.7.5.1.2.1</oid>
  <status>current</status>
  <PKTC-ACLS:access-control>AnyWritable</PKTC-ACLS:access-control>
  <user-hint>read-only</user-hint>
</xsd:appinfo>
<xsd:documentation>
  This data element MUST identify a Line Number on an E-DVA
  </xsd:documentation>
</xsd:annotation>
<xsd:simpleType>
  <xsd:restriction base="smi:Integer32">
    <xsd:minInclusive value="1"/>
    <xsd:maxInclusive value="10"/>
  </xsd:restriction>
</xsd:simpleType>
</xsd:attribute>
</xsd:complexType>
<xsd:complexType name="pktcRSTEDVAAnsSupTableEntryType">
  <xsd:sequence>
    <xsd:element name="pktcRSTEDVAAnsSup" type="SNMPv2-TC:TruthValue"
default="false">
      <xsd:annotation>
        <xsd:appinfo>
          <maxAccess>read-write</maxAccess>
          <oid>1.3.6.1.4.1.4491.2.2.7.5.1.3.2.1.1.1</oid>
          <status>current</status>
          <default>false</default>
          <PKTC-ACLS:access-control>NetworkWritable</PKTC-ACLS:access-control>
          <user-hint>read-only</user-hint>
        </xsd:appinfo>
        <xsd:documentation>
          This data element specifies the Answer Supervision state.
          Answer Supervision (also called battery reversal, reverse DC bias,
          or Reverse Loop Current Feed) is signaled when the distant end
          answers a call originated by the CPE. Typically this signal is
          used to notify electronic equipment such as PBXs which have a local
          billing system that a call has been answered. When provisioned to do
          so, the E-DVA may reverse DC bias when a call has been answered.

          The default value for this object is 'false' indicating that
          Answer Supervision is disabled (off).

          The E-DVA MUST implement this element per the PacketCable
          Residential SIP Telephony E-DVA Specification.
        </xsd:documentation>
      </xsd:annotation>
    </xsd:element>
    <xsd:element name="eXTObjpktcRSTEDVAAnsSupTableEntry" type="CL-PKTC-
TC:PkTcPACMExtension" minOccurs="0">
      <xsd:annotation>
```

```

    <xsd:appinfo>
      <maxAccess>read-only</maxAccess>
      <oid>1.3.6.1.4.1.4491.2.2.7.5.1.3.2.1.1.2</oid>
      <status>current</status>
      <PKTC-ACLS:access-control>NetworkWritable</PKTC-ACLS:access-control>
      <user-hint>RW</user-hint>
    </xsd:appinfo>
    <xsd:documentation>
      Extension object for 'EDVAAnsSupTableEntry'.
    </xsd:documentation>
  </xsd:annotation>
</xsd:element>
<xsd:any namespace="##other" processContents="lax" minOccurs="0"
maxOccurs="unbounded"/>
</xsd:sequence>
<xsd:attribute name="pktcRSTEDVLineNumber" use="required">
  <xsd:annotation>
    <xsd:appinfo>
      <maxAccess>not-accessible</maxAccess>
      <oid>1.3.6.1.4.1.4491.2.2.7.5.1.2.1</oid>
      <status>current</status>
      <PKTC-ACLS:access-control>AnyWritable</PKTC-ACLS:access-control>
      <user-hint>read-only</user-hint>
    </xsd:appinfo>
    <xsd:documentation>
      This data element MUST identify a Line Number on an E-DVA
    </xsd:documentation>
  </xsd:annotation>
<xsd:simpleType>
  <xsd:restriction base="smi:Integer32">
    <xsd:minInclusive value="1"/>
    <xsd:maxInclusive value="10"/>
  </xsd:restriction>
</xsd:simpleType>
</xsd:attribute>
</xsd:complexType>
<xsd:complexType name="pktcRSTEDVAPrLossTableEntryType">
  <xsd:sequence>
    <xsd:element name="pktcRSTEDVAPrLossDA" minOccurs="0" default="6">
      <xsd:annotation>
        <xsd:appinfo>
          <maxAccess>read-write</maxAccess>
          <oid>1.3.6.1.4.1.4491.2.2.7.5.1.3.4.1.1.1</oid>
          <status>current</status>
          <default>6</default>
          <PKTC-ACLS:access-control>NetworkWritable</PKTC-ACLS:access-control>
          <user-hint>read-only</user-hint>
        </xsd:appinfo>
        <xsd:documentation>
          This data element specifies the provisioned loss parameter
          for the D/A direction (towards the subscriber) in dB.

          The E-DVA MUST implement this element per the PacketCable
          Residential
          SIP Telephony E-DVA Specification.
        </xsd:documentation>
      </xsd:annotation>
    </xsd:element>
    <xsd:simpleType>
      <xsd:restriction base="smi:Integer32">
        <xsd:minInclusive value="0"/>
        <xsd:maxInclusive value="12"/>
      </xsd:restriction>
    </xsd:simpleType>
  </xsd:sequence>
  <xsd:element name="pktcRSTEDVAPrLossAD" default="6">
    <xsd:annotation>
      <xsd:appinfo>

```

```

        <maxAccess>read-write</maxAccess>
        <oid>1.3.6.1.4.1.4491.2.2.7.5.1.3.4.1.1.2</oid>
        <status>current</status>
        <default>6</default>
        <PKTC-ACLS:access-control>NetworkWritable</PKTC-ACLS:access-control>
        <user-hint>read-only</user-hint>
    </xsd:appinfo>
    <xsd:documentation>
        This data element specifies the provisioned loss parameter
        for the A/D direction (from the subscriber)in dB.

        The E-DVA MUST implement this element per the PacketCable
Residential SIP Telephony E-DVA Specification.
    </xsd:documentation>
</xsd:annotation>
<xsd:simpleType>
    <xsd:restriction base="smi:Integer32">
        <xsd:minInclusive value="0"/>
        <xsd:maxInclusive value="12"/>
    </xsd:restriction>
</xsd:simpleType>
</xsd:element>
<xsd:element name="eXTOBJpktcRSTEDVAPrLossTableEntry" type="CL-PKTC-
TC:PktcPACMExtension" minOccurs="0">
    <xsd:annotation>
        <xsd:appinfo>
            <maxAccess>read-only</maxAccess>
            <oid>1.3.6.1.4.1.4491.2.2.7.5.1.3.4.1.1.3</oid>
            <status>current</status>
            <PKTC-ACLS:access-control>NetworkWritable</PKTC-ACLS:access-control>
            <user-hint>RW</user-hint>
        </xsd:appinfo>
        <xsd:documentation>
            Extension object for 'pktcRSTEDVAPrLossTableEntry'.
        </xsd:documentation>
    </xsd:annotation>
</xsd:element>
<xsd:any namespace="##other" processContents="lax" minOccurs="0"
maxOccurs="unbounded"/>
</xsd:sequence>
<xsd:attribute name="pktcRSTEDVALineNumber" use="required">
    <xsd:annotation>
        <xsd:appinfo>
            <maxAccess>not-accessible</maxAccess>
            <oid>1.3.6.1.4.1.4491.2.2.7.5.1.2.1</oid>
            <status>current</status>
            <PKTC-ACLS:access-control>AnyWritable</PKTC-ACLS:access-control>
            <user-hint>read-only</user-hint>
        </xsd:appinfo>
        <xsd:documentation>
            This data element MUST identify a Line Number on an E-DVA
        </xsd:documentation>
    </xsd:annotation>
</xsd:simpleType>
    <xsd:restriction base="smi:Integer32">
        <xsd:minInclusive value="1"/>
        <xsd:maxInclusive value="10"/>
    </xsd:restriction>
</xsd:simpleType>
</xsd:attribute>
</xsd:complexType>
<xsd:complexType name="pktcRSTEDVADCBiasTableEntryType">
    <xsd:sequence>
        <xsd:element name="pktcRSTEDVADCBiasSig" type="SNMPv2-TC:TruthValue"
default="false">
            <xsd:annotation>

```

```

<xsd:appinfo>
  <maxAccess>read-write</maxAccess>
  <oid>1.3.6.1.4.1.4491.2.2.7.5.1.3.5.1.1.1</oid>
  <status>current</status>
  <default>false</default>
  <PKTC-ACLS:access-control>NetworkWritable</PKTC-ACLS:access-control>
  <user-hint>read-only</user-hint>
</xsd:appinfo>

```

```
<xsd:documentation>
```

This data element enables/disables the DCbias management per provisioned values on a per telephony port basis.

A default value of '0'(false)indicates that DCbias must perform per provisioned elements.

A value of '1' (true) indicates that the DCbias is not controlled by the provisioned elements.

The E-DVA MUST implement this element per the PacketCable

Residential

SIP Telephony E-DVA Specification.

```
</xsd:documentation>
```

```
</xsd:annotation>
```

```
</xsd:element>
```

```
<xsd:element name="pktcRSTEDVADCBiasMax" default="1200">
```

```
<xsd:annotation>
```

```
<xsd:appinfo>
```

```
<maxAccess>read-write</maxAccess>
```

```
<oid>1.3.6.1.4.1.4491.2.2.7.5.1.3.5.1.1.2</oid>
```

```
<status>current</status>
```

```
<default>1200</default>
```

```
<PKTC-ACLS:access-control>NetworkWritable</PKTC-ACLS:access-control>
```

```
<user-hint>read-only</user-hint>
```

```
</xsd:appinfo>
```

```
<xsd:documentation>
```

This data element specifies the maximum period of time, in seconds, that a DCbias must be maintained following an E-DVA reboot requiring a 'In-Service' State re-establishment.

The E-DVA MUST implement this element per the PacketCable

Residential

SIP Telephony E-DVA Specification.

```
</xsd:documentation>
```

```
</xsd:annotation>
```

```
<xsd:simpleType>
```

```
<xsd:restriction base="smi:Integer32">
```

```
<xsd:minInclusive value="0"/>
```

```
<xsd:maxInclusive value="2400"/>
```

```
</xsd:restriction>
```

```
</xsd:simpleType>
```

```
</xsd:element>
```

```
<xsd:element name="pktcRSTEDVADCBiasHold" default="600">
```

```
<xsd:annotation>
```

```
<xsd:appinfo>
```

```
<maxAccess>read-write</maxAccess>
```

```
<oid>1.3.6.1.4.1.4491.2.2.7.5.1.3.5.1.1.3</oid>
```

```
<status>current</status>
```

```
<default>600</default>
```

```
<PKTC-ACLS:access-control>NetworkWritable</PKTC-ACLS:access-control>
```

```
<user-hint>read-only</user-hint>
```

```
</xsd:appinfo>
```

```
<xsd:documentation>
```

This data element specifies the period of time, in seconds, that a DCbias must be maintained following an Out-of-Service State. If the DCbiasHold duration expires, the DCbias must be removed from the telephony port.

If the Network/E-DVA succeeds to re-establish the 'In-Service' state during the DCbiasHold duration, the DCbiasHold must be cancelled resulting in the DCbias being maintained on the telephony port in support of normal telephony signaling requirements.

The E-DVA MUST implement this element per the PacketCable Residential

```
SIP Telephony E-DVA Specification.
  </xsd:documentation>
</xsd:annotation>
<xsd:simpleType>
  <xsd:restriction base="smi:Integer32">
    <xsd:minInclusive value="0"/>
    <xsd:maxInclusive value="1200"/>
  </xsd:restriction>
</xsd:simpleType>
</xsd:element>
<xsd:element name="pktcRSTEDVADCBiasEnable" default="5">
  <xsd:annotation>
    <xsd:appinfo>
      <maxAccess>read-write</maxAccess>
      <oid>1.3.6.1.4.1.4491.2.2.7.5.1.3.5.1.1.4</oid>
      <status>current</status>
      <default>5</default>
      <PKTC-ACLS:access-control>NetworkWritable</PKTC-ACLS:access-control>
      <user-hint>read-only</user-hint>
    </xsd:appinfo>
    <xsd:documentation>
      This data element specifies the delay time period prior to
      reapplying DCbias on the E-DVA telephony port following the
      re-establishment of the 'In-Service' state following a DCbias
      removal. This avoids 'race' conditions between the Network/E-DVA
      transitions from inappropriately signaling to the end user
      security system.
    </xsd:documentation>
  </xsd:annotation>
</xsd:element>
```

The E-DVA MUST implement this element per the PacketCable Residential

```
SIP Telephony E-DVA Specification.
  </xsd:documentation>
</xsd:annotation>
<xsd:simpleType>
  <xsd:restriction base="smi:Integer32">
    <xsd:minInclusive value="0"/>
    <xsd:maxInclusive value="60"/>
  </xsd:restriction>
</xsd:simpleType>
</xsd:element>
<xsd:element name="eXTOBJpktcRSTEDVADCBiasTableEntry" type="CL-PKTC-
TC:PkTcPACMExtension" minOccurs="0">
  <xsd:annotation>
    <xsd:appinfo>
      <maxAccess>read-only</maxAccess>
      <oid>1.3.6.1.4.1.4491.2.2.7.5.1.3.5.1.1.5</oid>
      <status>current</status>
      <PKTC-ACLS:access-control>NetworkWritable</PKTC-ACLS:access-control>
      <user-hint>RW</user-hint>
    </xsd:appinfo>
    <xsd:documentation>
      Extension object for 'pktcRSTEDVADCBiasTableEntry'.
    </xsd:documentation>
  </xsd:annotation>
</xsd:element>
  <xsd:any namespace="##other" processContents="lax" minOccurs="0"
maxOccurs="unbounded"/>
</xsd:sequence>
  <xsd:attribute name="pktcRSTEDVALineNumber" use="required">
```

```
<xsd:annotation>
  <xsd:appinfo>
    <maxAccess>not-accessible</maxAccess>
    <oid>1.3.6.1.4.1.4491.2.2.7.5.1.2.1</oid>
    <status>current</status>
    <PKTC-ACLS:access-control>AnyWritable</PKTC-ACLS:access-control>
    <user-hint>read-only</user-hint>
  </xsd:appinfo>
  <xsd:documentation>
    This data element MUST identify a Line Number on an E-DVA
  </xsd:documentation>
</xsd:annotation>
<xsd:simpleType>
  <xsd:restriction base="smi:Integer32">
    <xsd:minInclusive value="1"/>
    <xsd:maxInclusive value="10"/>
  </xsd:restriction>
</xsd:simpleType>
</xsd:attribute>
</xsd:complexType>
</xsd:schema>
```

## Appendix I RST-PACM SMI Definitions

### I.1 SMI representation of the RST Feature Profile

```
CL-PKTC-RST DEFINITIONS ::= BEGIN

IMPORTS

    MODULE-IDENTITY,
    OBJECT-TYPE,
    Integer32
        FROM SNMPv2-SMI
    OBJECT-GROUP,
    MODULE-COMPLIANCE
        FROM SNMPv2-CONF
    SnmpAdminString
        FROM SNMP-FRAMEWORK-MIB

    TEXTUAL-CONVENTION,
    TruthValue
        FROM SNMPv2-TC
    PktcPACMExtension
        FROM CL-PKTC-TC
    pktcPACMMibs
        FROM CLAB-DEF-MIB;

pktcPACMRSTMib MODULE-IDENTITY
    LAST-UPDATED "200609270000Z" -- September 27, 2006
    ORGANIZATION "Cable Television Laboratories, Inc."
    CONTACT-INFO
        "Cable Television Laboratories, Inc.
        858 Coal Creek Circle,
        Louisville, CO 80027, USA
        +1 303-661-3307
        mibs@cablelabs.com"

    DESCRIPTION
        "This MIB module contains configuration MIB
        objects for the RST Features as required by
        the PacketCable Residential SIP Telephony (RST)
        Provisioning, Activation, Configuration and
        Management(PACM) specification."
    ::= { pktcPACMMibs 4 }

-- Administrative assignments
pktcPACMRSTNotifications OBJECT IDENTIFIER ::= { pktcPACMRSTMib 0 }
pktcPACMRSTObjects OBJECT IDENTIFIER ::= { pktcPACMRSTMib 1 }
pktcPACMRSTConformance OBJECT IDENTIFIER ::= { pktcPACMRSTMib 2 }

pktcPACMRSTCompliances OBJECT IDENTIFIER ::= { pktcPACMRSTConformance 1 }
pktcPACMRSTGroups OBJECT IDENTIFIER ::= { pktcPACMRSTConformance 2 }

-- MIB Objects
pktcPACMRSTProfileIDs OBJECT IDENTIFIER ::= { pktcPACMRSTObjects 2 }
pktcPACMRSTProfile OBJECT IDENTIFIER ::= { pktcPACMRSTObjects 3 }

-----
-- Minor version
-----
pktcPACMRSTMinorVersion OBJECT-TYPE
    SYNTAX Integer32
    MAX-ACCESS read-only
```

```

STATUS      current
DESCRIPTION
  "PACM-ACCESS:NW:RO:MA
  The default value of this MIB Object contains the minor version
  of the data model."
DEFVAL {0}
 ::= { pktcPACMRSTObjects 1 }

-----
-- Extension Object
-----

exTOBJpktcRSTObjects OBJECT-TYPE
SYNTAX      PktcPACMExtension
MAX-ACCESS  read-only
STATUS      current
DESCRIPTION
  "PACM-ACCESS:NW:RW:OP
  Extension object for 'pktcRSTObjects'."
 ::= { pktcPACMRSTObjects 4 }

-----
-- Pktc PACM RST Textual Conventions
-----

PktcRSTDIGITMAP ::= TEXTUAL-CONVENTION
STATUS current
DESCRIPTION
  "This TEXTUAL CONVENTION is being defined
  as a way of indicating:
  - Digit Map
  In the associated XML Schema definitions,
  this is expected to be defined as indicated
  in the XML snippet below."
-- <xsd:simpleType name="pktcRSTDigitMapPattern">
-- <xsd:annotation>
-- <xsd:documentation>
--   A digit map pattern. Refer to the PacketCable RST
--   Feature specification for detailed syntax and
--   semantics.
-- </xsd:documentation>
-- </xsd:annotation>
-- <xsd:restriction base="xsd:string"/>
-- </xsd:simpleType>
--
-- <xsd:simpleType name="pktcRSTDigitMapActionArg">
-- <xsd:annotation>
-- <xsd:documentation>
--   A digit map action argument. Refer to the PacketCable RST
--   Feature specification for detailed syntax and
--   semantics
-- </xsd:documentation>
-- </xsd:annotation>
-- <xsd:restriction base="xsd:string"/>
-- </xsd:simpleType>
--
-- <xsd:element name="pktcRSTTimers">
-- <xsd:annotation>
-- <xsd:documentation>
--   Short Interdigit Timer: Used when critical timing should be
--   performed, such as when the dialed digits constitute a complete
--   address, but additional digits may constitute a different
--   complete address.
--   For more info, refer to the PacketCable RST Feature specification
-- </xsd:documentation>
-- </xsd:annotation>
--
-- <xsd:complexType>

```

```
--
-- <xsd:attribute name="pktcRSTAttrT" type="xsd:decimal" use="optional">
--   <xsd:annotation>
--     <xsd:documentation>
--       Start Timer: The length of time allowed to dial the first
--       digit from the time dial tone is applied.
--     </xsd:documentation>
--   </xsd:annotation>
-- </xsd:attribute>
--
-- <xsd:attribute name="pktcRSTAttrS" type="xsd:decimal" use="optional"/>
--
-- <xsd:attribute name="pktcRSTAttrL" type="xsd:decimal" use="optional">
--   <xsd:annotation>
--     <xsd:documentation>
--       Long Interdigit Timer: Long interdigit timer. The allowable time
--       between digits if the short interdigit timer has not been
--       indicated in the digitmap.
--     </xsd:documentation>
--   </xsd:annotation>
-- </xsd:attribute>
--
-- <xsd:attribute name="pktcRSTAttrZ" type="xsd:decimal" use="optional">
--   <xsd:annotation>
--     <xsd:documentation>
--       Long Duration Timer: The duration a particular digit is to be
--       held in order to be detected. When a Z is placed in a pattern,
--       the Long Duration Timer is applied to the following key in the
--       pattern.
--     </xsd:documentation>
--   </xsd:annotation>
-- </xsd:attribute>
--
-- </xsd:complexType>
-- </xsd:element>
--
-- <xsd:complexType name="pktcRSTActionType"/>
-- <xsd:element name="pktcRSTRule">
--   <xsd:annotation>
--     <xsd:documentation>
--       A Digit map rule
--     </xsd:documentation>
--   </xsd:annotation>
-- </xsd:element>
--
-- <xsd:complexType>
--   <xsd:sequence>
--     <xsd:element name="pktcRSTPattern" type="pktcRSTDigitMapPattern"/>
--     <xsd:choice minOccurs="0" maxOccurs="unbounded">
--       <xsd:element name="pktcRSTReturn" type="pktcRSTDigitMapActionArg"/>
--       <xsd:element name="pktcRSTUseMap" type="pktcRSTDigitMapActionArg"/>
--       <xsd:element name="pktcRSTCall" type="pktcRSTDigitMapActionArg"/>
--       <xsd:element name="pktcRSTHold"/>
--       <xsd:element name="pktcRSTRecall"/>
--       <xsd:element name="pktcRSTReorder"/>
--       <xsd:element name="pktcRSTAcrrActivate"/>
--       <xsd:element name="pktcRSTAcrrDeactivate"/>
--       <xsd:element name="pktcRSTAC"/>
--       <xsd:element name="pktcRSTAR"/>
--       <xsd:element name="pktcRSTCIDSuppress"/>
--       <xsd:element name="pktcRSTCIDDeliver"/>
--       <xsd:element name="pktcRSTCOT"/>
--       <xsd:element name="pktcRSTCWToggle"/>
--       <xsd:element name="pktcRSTCFVProgram"/>
--       <xsd:element name="pktcRSTDNDProgram"/>
--       <xsd:element name="pktcRSTSCFProgram"/>
--       <xsd:element name="pktcRSTSBMaint"/>
--       <xsd:element name="pktcRSTSDProgram"/>
--     </xsd:choice>
--   </xsd:sequence>
-- </xsd:complexType>
```

```

--      <xsd:element name="pktcRSTSPPPProgram"/>
--      <xsd:element name="pktcRSTEmergencyCall"/>
--    </xsd:choice>
--  </xsd:sequence>
-- </xsd:complexType>
-- </xsd:element>
--
-- <xsd:element name="pktcRSTSymbolDef">
--   <xsd:annotation>
--     <xsd:documentation>
--       A symbol or variable definition, for use in patterns or
--       action arguments
--     </xsd:documentation>
--   </xsd:annotation>
-- <xsd:complexType>
--
--   <xsd:simpleContent>
--     <xsd:extension base="xsd:string">
--       <xsd:attribute name="pktcRSTAttrName" type="xsd:string" use="required"/>
--     </xsd:extension>
--   </xsd:simpleContent>
-- </xsd:complexType>
-- </xsd:element>
--
-- <xsd:element name="pktcRSTMapDef">
--   <xsd:annotation>
--     <xsd:documentation>
--       A digit map definition
--     </xsd:documentation>
--   </xsd:annotation>
--
--   <xsd:complexType>
--     <xsd:sequence>
--       <xsd:element ref="pktcRSTRule" minOccurs="0" maxOccurs="unbounded"/>
--     </xsd:sequence>
--     <xsd:attribute name="pktcRSTAttrName" type="xsd:string" use="required"/>
--   </xsd:complexType>
-- </xsd:element>
--
-- <xsd:complexType name="PktcRSTDIGITMAP">
--   <xsd:sequence>
--     <xsd:element ref="pktcRSTTimers"/>
--     <xsd:element ref="pktcRSTSymbolDef" minOccurs="0" maxOccurs="unbounded"/>
--     <xsd:element ref="pktcRSTMapDef" maxOccurs="unbounded"/>
--   </xsd:sequence>
-- </xsd:complexType>
--
--       SYNTAX   OCTET STRING

```

PktcRSTTONEANNC ::= TEXTUAL-CONVENTION

```

--   STATUS   current
--   DESCRIPTION
--     "This TEXTUAL CONVENTION is being defined
--     as a way of indicating:
--       - Tone,
--       - Announcement
--     In the associated XML Schema definitions,
--     this is expected to be defined as indicated
--     in the comments that follow."
-- <xsd:complexType name="PktcRSTTONEANNC">
--   <xsd:choice>
--     <xsd:element name="tone" type="xsd:anyURI"/>
--     <xsd:element name="announcement" type="xsd:string"/>
--   </xsd:choice>
-- </xsd:complexType>
--
--       SYNTAX   OCTET STRING

```

```
-----
-- The Basic Call Features
-- Ref (PacketCable RST specification): Table "Basic Call Feature Data"
-----
pktcRSTBasicCallFeatProfile OBJECT IDENTIFIER ::= { pktcPACMRSTProfile 1 }

pktcRSTBasicCallDigitMap OBJECT-TYPE
    SYNTAX      PktcRSTDIGITMAP
    MAX-ACCESS  read-write
    STATUS      current
    DESCRIPTION
        "PACM-ACCESS:NW:RO:MA
        This data element specifies the basic call digit map."
    REFERENCE  "PacketCable Residential SIP Telephony Feature Specification"
    ::= { pktcRSTBasicCallFeatProfile 1 }

pktcRSTBasicCallSDP OBJECT-TYPE
    SYNTAX      SnmpAdminString
    MAX-ACCESS  read-write
    STATUS      current
    DESCRIPTION
        "PACM-ACCESS:NW:RO:MA
        This data element specifies the SDP parameters and value."
    REFERENCE  "PacketCable Residential SIP Telephony Feature Specification"
    ::= { pktcRSTBasicCallFeatProfile 2 }

pktcRSTBasicCallByeDelay OBJECT-TYPE
    SYNTAX      Integer32
    MAX-ACCESS  read-write
    STATUS      current
    DESCRIPTION
        "PACM-ACCESS:NW:RO:MA
        This data element specifies the Bye Delay in seconds."
    REFERENCE  "PacketCable Residential SIP Telephony Feature Specification"
    ::= { pktcRSTBasicCallFeatProfile 3 }

pktcRSTBasicCallOrigDTTimer OBJECT-TYPE
    SYNTAX      Integer32
    MAX-ACCESS  read-write
    STATUS      current
    DESCRIPTION
        "PACM-ACCESS:NW:RO:MA
        This data element specifies the Origination Mode
        Dial Tone Timer in seconds."
    REFERENCE  "PacketCable Residential SIP Telephony Feature Specification"
    ::= { pktcRSTBasicCallFeatProfile 4 }

pktcRSTBasicCallTermOHErrorSignal OBJECT-TYPE
    SYNTAX      PktcRSTTONEANNC
    MAX-ACCESS  read-write
    STATUS      current
    DESCRIPTION
        "PACM-ACCESS:NW:RO:MA
        This data element specifies the Termination Mode Off-Hook
        error signal."
    REFERENCE  "PacketCable Residential SIP Telephony Feature Specification"
    ::= { pktcRSTBasicCallFeatProfile 5 }

pktcRSTBasicCallTermErrSignalTimer OBJECT-TYPE
    SYNTAX      Integer32
    MAX-ACCESS  read-write
    STATUS      current
    DESCRIPTION
        "PACM-ACCESS:NW:RO:MA
        This data element specifies the Termination Mode
        error signal timer in seconds."
    REFERENCE  "PacketCable Residential SIP Telephony Feature Specification"
```

```

 ::= { pktcRSTBasicCallFeatProfile 6 }

pktcRSTBasicCallPermSeqTone1 OBJECT-TYPE
    SYNTAX      PktcRSTTONEANNC
    MAX-ACCESS  read-write
    STATUS      current
    DESCRIPTION
        "PACM-ACCESS:NW:RO:MA
         This data element specifies the Permanent Sequence
         tone 1."
    REFERENCE  "PacketCable Residential SIP Telephony Feature Specification"
    ::= { pktcRSTBasicCallFeatProfile 7 }

pktcRSTBasicCallPermSeqTimer1 OBJECT-TYPE
    SYNTAX      Integer32
    MAX-ACCESS  read-write
    STATUS      current
    DESCRIPTION
        "PACM-ACCESS:NW:RO:MA
         This data element specifies the Permanent Sequence
         timer 1 in seconds."
    REFERENCE  "PacketCable Residential SIP Telephony Feature Specification"
    ::= { pktcRSTBasicCallFeatProfile 8 }

pktcRSTBasicCallPermSeqTone2 OBJECT-TYPE
    SYNTAX      PktcRSTTONEANNC
    MAX-ACCESS  read-write
    STATUS      current
    DESCRIPTION
        "PACM-ACCESS:NW:RO:MA
         This data element specifies the Permanent Sequence
         tone 2."
    REFERENCE  "PacketCable Residential SIP Telephony Feature Specification"
    ::= { pktcRSTBasicCallFeatProfile 9 }

pktcRSTBasicCallPermSeqTimer2 OBJECT-TYPE
    SYNTAX      Integer32
    MAX-ACCESS  read-write
    STATUS      current
    DESCRIPTION
        "PACM-ACCESS:NW:RO:MA
         This data element specifies the Permanent Sequence
         timer 2 in seconds."
    REFERENCE  "PacketCable Residential SIP Telephony Feature Specification"
    ::= { pktcRSTBasicCallFeatProfile 10 }

pktcRSTBasicCallPermSeqTone3 OBJECT-TYPE
    SYNTAX      PktcRSTTONEANNC
    MAX-ACCESS  read-write
    STATUS      current
    DESCRIPTION
        "PACM-ACCESS:NW:RO:MA
         This data element specifies the Permanent Sequence
         tone 3."
    REFERENCE  "PacketCable Residential SIP Telephony Feature Specification"
    ::= { pktcRSTBasicCallFeatProfile 11 }

pktcRSTBasicCallPermSeqTimer3 OBJECT-TYPE
    SYNTAX      Integer32
    MAX-ACCESS  read-write
    STATUS      current
    DESCRIPTION
        "PACM-ACCESS:NW:RO:MA
         This data element specifies the Permanent Sequence
         timer 3 in seconds."
    REFERENCE  "PacketCable Residential SIP Telephony Feature Specification"
    ::= { pktcRSTBasicCallFeatProfile 12 }

```

```
pktcRSTBasicCallLORTimer OBJECT-TYPE
    SYNTAX      Integer32
    MAX-ACCESS  read-write
    STATUS      current
    DESCRIPTION
        "PACM-ACCESS:NW:RO:MA
        This data element specifies the Lockout Reset
        timer in seconds."
    REFERENCE  "PacketCable Residential SIP Telephony Feature Specification"
    ::= { pktcRSTBasicCallFeatProfile 13 }

exTOBJpktcRSTBasicCallFeatProfile OBJECT-TYPE
    SYNTAX      PktpACMExtension
    MAX-ACCESS  read-only
    STATUS      current
    DESCRIPTION
        "PACM-ACCESS:NW:RW:OP
        Extension object for 'pktcRSTBasicCallFeatProfile'."
    ::= { pktcRSTBasicCallFeatProfile 14 }

-----
-- PktpACM RST Announcement Feature Profile
-- Ref (PacketCable RST specification): Table "Announcement Feature Data"
-----
pktcRSTAncFeatProfile OBJECT IDENTIFIER ::= { pktpACMRSTProfile 2 }

pktcRSTAncRes OBJECT-TYPE
    SYNTAX      SnmpAdminString
    MAX-ACCESS  read-write
    STATUS      current
    DESCRIPTION
        "PACM-ACCESS:NW:RO:MA
        This data element specifies the Announcement Resource
        URI for the media server"
    REFERENCE  "PacketCable Residential SIP Telephony Feature Specification"
    ::= { pktcRSTAncFeatProfile 1 }

pktcRSTAncDomain OBJECT-TYPE
    SYNTAX      SnmpAdminString
    MAX-ACCESS  read-write
    STATUS      current
    DESCRIPTION
        "PACM-ACCESS:NW:RO:MA
        This data element specifies the Announcement Domain."
    REFERENCE  "PacketCable Residential SIP Telephony Feature Specification"
    ::= { pktcRSTAncFeatProfile 2 }

pktcRSTAncPath OBJECT-TYPE
    SYNTAX      SnmpAdminString
    MAX-ACCESS  read-write
    STATUS      current
    DESCRIPTION
        "PACM-ACCESS:NW:RO:MA
        This data element specifies the Announcement Path."
    REFERENCE  "PacketCable Residential SIP Telephony Feature Specification"
    ::= { pktcRSTAncFeatProfile 3 }

pktcRSTAncMIMEType OBJECT-TYPE
    SYNTAX      SnmpAdminString
    MAX-ACCESS  read-write
    STATUS      current
    DESCRIPTION
        "PACM-ACCESS:NW:RO:MA
        This data element specifies the Announcement MIME type."
    REFERENCE  "PacketCable Residential SIP Telephony Feature Specification"
    ::= { pktcRSTAncFeatProfile 4 }
```

```

pktcRSTAncMapTable OBJECT-TYPE
    SYNTAX      SEQUENCE OF PktcRSTAncMapEntry
    MAX-ACCESS  not-accessible
    STATUS      current
    DESCRIPTION
        "PACM-ACCESS:NW:RO:OP
         This data table represents the announcement MAP entries"
    REFERENCE  "PacketCable Residential SIP Telephony Feature Specification"
    ::= { pktcRSTAncFeatProfile 5 }

pktcRSTAncMapEntry OBJECT-TYPE
    SYNTAX      PktcRSTAncMapEntry
    MAX-ACCESS  not-accessible
    STATUS      current
    DESCRIPTION
        "PACM-ACCESS:NW:RO:OP
         This data table represents the announcement MAP entries.
         Each entry in this table represents the Announcement MAP
         entry URI corresponding to a response code."
    REFERENCE  "PacketCable Residential SIP Telephony Feature Specification"
    INDEX      {pktcRSTAncRspCode}
    ::= { pktcRSTAncMapTable 1 }

PktcRSTAncMapEntry ::=
    SEQUENCE {
        pktcRSTAncRspCode      Integer32,
        pktcRSTAncURI          SnmpAdminString,
        eXTOBJpktcRSTAncMapEntry  PktcPACMExtension
    }

pktcRSTAncRspCode OBJECT-TYPE
    SYNTAX      Integer32(0..32000)
    MAX-ACCESS  not-accessible
    STATUS      current
    DESCRIPTION
        "PACM-ACCESS:NW:RO:MA
         This data element specifies the Response code."
    REFERENCE  "PacketCable Residential SIP Telephony Feature Specification"
    ::= { pktcRSTAncMapEntry 1 }

pktcRSTAncURI OBJECT-TYPE
    SYNTAX      SnmpAdminString
    MAX-ACCESS  read-write
    STATUS      current
    DESCRIPTION
        "PACM-ACCESS:NW:RO:MA
         This data element specifies the Announcement Map entry.
         A string identifying the URI for response code."
    REFERENCE  "PacketCable Residential SIP Telephony Feature Specification"
    ::= { pktcRSTAncMapEntry 2 }

eXTOBJpktcRSTAncMapEntry OBJECT-TYPE
    SYNTAX      PktcPACMExtension
    MAX-ACCESS  read-only
    STATUS      current
    DESCRIPTION
        "PACM-ACCESS:NW:RW:OP
         Extension object for 'pktcRSTAncMapEntry'."
    ::= { pktcRSTAncMapEntry 3 }

pktcRSTAncMediaMapTable OBJECT-TYPE
    SYNTAX      SEQUENCE OF PktcRSTAncMediaMapEntry
    MAX-ACCESS  not-accessible
    STATUS      current
    DESCRIPTION
        "PACM-ACCESS:NW:RO:OP

```

This data table represents the announcement Media MAP entries"  
REFERENCE "PacketCable Residential SIP Telephony Feature Specification"  
::= { pktcRSTAncFeatProfile 6 }

pktcRSTAncMediaMapEntry OBJECT-TYPE  
SYNTAX PktcRSTAncMediaMapEntry  
MAX-ACCESS not-accessible  
STATUS current  
DESCRIPTION  
"PACM-ACCESS:NW:RO:OP  
This data table represents the announcement Media MAP entries.  
Each entry in this table represents the Announcement Media MAP  
entry URI corresponding to an announcement identifier."  
REFERENCE "PacketCable Residential SIP Telephony Feature Specification"  
INDEX {pktcRSTAncMediaId}  
::= { pktcRSTAncMediaMapTable 1 }

PktcRSTAncMediaMapEntry ::=  
SEQUENCE {  
    pktcRSTAncMediaId SnmpAdminString,  
    pktcRSTAncMediaURI SnmpAdminString,  
    eXTObjpktcRSTAncMediaMapEntry PktcPACMExtension  
}

pktcRSTAncMediaId OBJECT-TYPE  
SYNTAX SnmpAdminString  
MAX-ACCESS not-accessible  
STATUS current  
DESCRIPTION  
"PACM-ACCESS:NW:RO:MA  
This data element specifies the announcement Identifier."  
REFERENCE "PacketCable Residential SIP Telephony Feature Specification"  
::= { pktcRSTAncMediaMapEntry 1 }

pktcRSTAncMediaURI OBJECT-TYPE  
SYNTAX SnmpAdminString  
MAX-ACCESS read-write  
STATUS current  
DESCRIPTION  
"PACM-ACCESS:NW:RO:MA  
This data element specifies the Announcement Media Map entry.  
A string identifying the URI for announcement identifier."  
REFERENCE "PacketCable Residential SIP Telephony Feature Specification"  
::= { pktcRSTAncMediaMapEntry 2 }

eXTObjpktcRSTAncMediaMapEntry OBJECT-TYPE  
SYNTAX PktcPACMExtension  
MAX-ACCESS read-only  
STATUS current  
DESCRIPTION  
"PACM-ACCESS:NW:RW:OP  
Extension object for 'pktcRSTAncMediaMapEntry'. "  
::= { pktcRSTAncMediaMapEntry 3 }

pktcRSTAncMediaCachMaxAge OBJECT-TYPE  
SYNTAX Integer32  
MAX-ACCESS read-write  
STATUS current  
DESCRIPTION  
"PACM-ACCESS:NW:RO:OP  
This data element specifies the Announcement Media Cache  
maximum age in seconds."  
REFERENCE "PacketCable Residential SIP Telephony Feature Specification"  
::= { pktcRSTAncFeatProfile 7 }

eXTObjpktcRSTAncFeatProfile OBJECT-TYPE  
SYNTAX PktcPACMExtension

```

MAX-ACCESS read-only
STATUS current
DESCRIPTION
    "PACM-ACCESS:NW:RW:OP
    Extension object for 'pktcRSTAncFeatProfile'."
 ::= { pktcRSTAncFeatProfile 8 }

-----
-- Pktc PACM RST Local Media Feature Profile
-- Ref (PacketCable RST specification): "UE Local Media"
-----
pktcRSTLocalMediaProfile OBJECT IDENTIFIER ::= { pktcPACMRSTProfile 3 }

pktcRSTLocalMediaTable OBJECT-TYPE
    SYNTAX SEQUENCE OF PktcRSTLocalMediaEntry
    MAX-ACCESS not-accessible
    STATUS current
    DESCRIPTION
        "PACM-ACCESS:NW:RO:OP
        This data table represents the Local Media entries"
    REFERENCE "PacketCable Residential SIP Telephony Feature Specification"
    ::= { pktcRSTLocalMediaProfile 1 }

pktcRSTLocalMediaEntry OBJECT-TYPE
    SYNTAX PktcRSTLocalMediaEntry
    MAX-ACCESS not-accessible
    STATUS current
    DESCRIPTION
        "PACM-ACCESS:NW:RO:OP
        Each entry in this table represents the Local Media
        entries."
    INDEX {pktcRSTLocalMediaURI}
    ::= { pktcRSTLocalMediaTable 1 }

PktcRSTLocalMediaEntry ::=
    SEQUENCE {
        pktcRSTLocalMediaURI SnmpAdminString,
        pktcRSTLocalMediaType SnmpAdminString,
        pktcRSTLocalMediaData SnmpAdminString,
        eXTObjpktcRSTLocalMediaEntry PktcPACMExtension
    }

pktcRSTLocalMediaURI OBJECT-TYPE
    SYNTAX SnmpAdminString
    MAX-ACCESS not-accessible
    STATUS current
    DESCRIPTION
        "PACM-ACCESS:NW:RO:MA
        This data element specifies the Local Media entry.
        A string identifying the URI for the Local Media."
    REFERENCE "PacketCable Residential SIP Telephony Feature Specification"
    ::= { pktcRSTLocalMediaEntry 1 }

pktcRSTLocalMediaType OBJECT-TYPE
    SYNTAX SnmpAdminString
    MAX-ACCESS read-write
    STATUS current
    DESCRIPTION
        "PACM-ACCESS:NW:RO:MA
        This data element specifies the Media Type entry."
    REFERENCE "PacketCable Residential SIP Telephony Feature Specification"
    ::= { pktcRSTLocalMediaEntry 2 }

pktcRSTLocalMediaData OBJECT-TYPE
    SYNTAX SnmpAdminString
    MAX-ACCESS read-write
    STATUS current

```

```
DESCRIPTION
  "PACM-ACCESS:NW:RO:MA
  This data element specifies the Media Data entry."
REFERENCE "PacketCable Residential SIP Telephony Feature Specification"
 ::= { pktcRSTLocalMediaEntry 3 }

eXTOBJpktcRSTLocalMediaEntry OBJECT-TYPE
SYNTAX      PktcPACMExtension
MAX-ACCESS  read-only
STATUS      current
DESCRIPTION
  "PACM-ACCESS:NW:RW:OP
  Extension object for 'pktcRSTLocalMediaEntry'."
 ::= { pktcRSTLocalMediaEntry 4 }

eXTOBJpktcRSTLocalMediaProfile OBJECT-TYPE
SYNTAX      PktcPACMExtension
MAX-ACCESS  read-only
STATUS      current
DESCRIPTION
  "PACM-ACCESS:NW:RW:OP
  Extension object for 'pktcRSTLocalMediaProfile'."
 ::= { pktcRSTLocalMediaProfile 3 }

-----
-- Pktc PACM RST UE Announcement Language Feature Profile
-- Ref (PacketCable RST specification): "UE Announcement Language Preference
-- Feature Data"
-----
pktcRSTAncLangProfile OBJECT IDENTIFIER ::= { pktcPACMRSTProfile 4 }

pktcRSTAncLangPrefLang OBJECT-TYPE
SYNTAX      SnmpAdminString
MAX-ACCESS  read-write
STATUS      current
DESCRIPTION
  "PACM-ACCESS:NW:RO:MA
  This data element specifies the preferred language for the
  UE announcement."
REFERENCE "PacketCable Residential SIP Telephony Feature Specification"
 ::= { pktcRSTAncLangProfile 1 }

eXTOBJpktcRSTAncLangProfile OBJECT-TYPE
SYNTAX      PktcPACMExtension
MAX-ACCESS  read-only
STATUS      current
DESCRIPTION
  "PACM-ACCESS:NW:RW:OP
  Extension object for 'pktcRSTAncLangProfile'."
 ::= { pktcRSTAncLangProfile 2 }

-----
-- Pktc PACM RST UE Status Change Feature Profile
-- Ref (PacketCable RST specification): "UE Status Change Feature Data"
-----
pktcRSTUEStatusChangeProfile OBJECT IDENTIFIER ::= { pktcPACMRSTProfile 5 }

pktcRSTUEStRegExp OBJECT-TYPE
SYNTAX      Integer32
MAX-ACCESS  read-write
STATUS      current
DESCRIPTION
  "PACM-ACCESS:NW:RW:OP
  This data element specifies the UE Status
  Registration expiration in seconds."
REFERENCE "PacketCable Residential SIP Telephony Feature Specification"
 ::= { pktcRSTUEStatusChangeProfile 1 }
```

```

eXTOBJpktcRSTUEStatusChangeProfile OBJECT-TYPE
    SYNTAX      PktcPACMExtension
    MAX-ACCESS  read-only
    STATUS      current
    DESCRIPTION
        "PACM-ACCESS:NW:RW:OP
         Extension object for 'pktcRSTUEStatusChangeProfile'."
    ::= { pktcRSTUEStatusChangeProfile 3 }

-----
-- Pktc PACM RST No Answer Timeout Feature Profile
-- Ref (PacketCable RST specification): "No Answer Timeout Feature Data"
-----
pktcRSTNoAnsTimeoutProfile OBJECT IDENTIFIER ::= { pktcPACMRSTProfile 6 }

pktcRSTNAnsTODuration OBJECT-TYPE
    SYNTAX      Integer32
    MAX-ACCESS  read-write
    STATUS      current
    DESCRIPTION
        "PACM-ACCESS:NW:RO:MA
         This data element specifies the No Answer Timeout Duration
         in seconds."
    REFERENCE  "PacketCable Residential SIP Telephony Feature Specification"
    ::= { pktcRSTNoAnsTimeoutProfile 1 }

eXTOBJpktcRSTNoAnsTimeoutProfile OBJECT-TYPE
    SYNTAX      PktcPACMExtension
    MAX-ACCESS  read-only
    STATUS      current
    DESCRIPTION
        "PACM-ACCESS:NW:RW:OP
         Extension object for 'pktcRSTNoAnsTimeoutProfile'."
    ::= { pktcRSTNoAnsTimeoutProfile 2 }

-----
-- Pktc PACM RST Caller ID Feature Profile
-- Ref (PacketCable RST specification): " Caller ID Feature Data"
-----
pktcRSTCallerIdProfile OBJECT IDENTIFIER ::= { pktcPACMRSTProfile 7 }

pktcRSTCIDPPS OBJECT-TYPE
    SYNTAX      INTEGER {
                    anonymous(1),
                    public(2)
                }
    MAX-ACCESS  read-write
    STATUS      current
    DESCRIPTION
        "PACM-ACCESS:NW:RO:MA
         This data element specifies the Permanent Presentation Status."
    REFERENCE  "PacketCable Residential SIP Telephony Feature Specification"
    ::= { pktcRSTCallerIdProfile 1 }

eXTOBJpktcRSTCallerIdProfile OBJECT-TYPE
    SYNTAX      PktcPACMExtension
    MAX-ACCESS  read-only
    STATUS      current
    DESCRIPTION
        "PACM-ACCESS:NW:RW:OP
         Extension object for 'pktcRSTCallerIdProfile'."
    ::= { pktcRSTCallerIdProfile 2 }

-----
-- Pktc PACM RST Caller ID Display Feature Profile
-- Ref (PacketCable RST specification): "Caller ID Display Feature Data"
-----

```

```
pktcRSTCIDDisplayProfile OBJECT IDENTIFIER ::= { pktcPACMRSTProfile 8 }

pktcRSTCIDCNDActStatus OBJECT-TYPE
    SYNTAX      TruthValue
    MAX-ACCESS  read-write
    STATUS      current
    DESCRIPTION
        "PACM-ACCESS:NW:RO:MA
        This data element specifies the activation status for Calling
        Number Display (CND)."
```

REFERENCE "PacketCable Residential SIP Telephony Feature Specification"  
 ::= { pktcRSTCIDDisplayProfile 1 }

```
pktcRSTCIDCNAMDActStatus OBJECT-TYPE
    SYNTAX      TruthValue
    MAX-ACCESS  read-write
    STATUS      current
    DESCRIPTION
        "PACM-ACCESS:NW:RO:MA
        This data element specifies the activation status for Calling
        Name Display (CNAMD)."
```

REFERENCE "PacketCable Residential SIP Telephony Feature Specification"  
 ::= { pktcRSTCIDDisplayProfile 2 }

```
pktcRSTCIDDispTimeAdj OBJECT-TYPE
    SYNTAX      Integer32
    MAX-ACCESS  read-write
    STATUS      current
    DESCRIPTION
        "PACM-ACCESS:NW:RO:MA
        This data element specifies UTC time adjustment
        in minutes."
```

REFERENCE "PacketCable Residential SIP Telephony Feature Specification"  
 ::= { pktcRSTCIDDisplayProfile 3 }

```
pktcRSTCIDDispDefCountry OBJECT-TYPE
    SYNTAX      SnmpAdminString
    MAX-ACCESS  read-write
    STATUS      current
    DESCRIPTION
        "PACM-ACCESS:NW:RO:MA
        This data element specifies default country code."
```

REFERENCE "PacketCable Residential SIP Telephony Feature Specification"  
 ::= { pktcRSTCIDDisplayProfile 4 }

```
eXTOBJpktcRSTCIDDisplayProfile OBJECT-TYPE
    SYNTAX      PktpACMExtension
    MAX-ACCESS  read-only
    STATUS      current
    DESCRIPTION
        "PACM-ACCESS:NW:RW:OP
        Extension object for 'pktcRSTCIDDisplayProfile'."
```

::= { pktcRSTCIDDisplayProfile 5 }

```
-----
-- Pktp PACM RST Caller ID Per Call Blocking Feature Profile
-- Ref (PacketCable RST specification): "Caller ID Per-Call Blocking Feature
Data"
-----
```

```
pktcRSTCIDCallBlkProfile OBJECT IDENTIFIER ::= { pktcPACMRSTProfile 9 }
```

```
pktcRSTCIDCBlkConfTone OBJECT-TYPE
    SYNTAX      PktpRSTTONEANNC
    MAX-ACCESS  read-write
    STATUS      current
    DESCRIPTION
        "PACM-ACCESS:NW:RO:MA
```

```

        This data element specifies the confirmation tone after
        vertical feature code."
REFERENCE "PacketCable Residential SIP Telephony Feature Specification"
 ::= { pktcRSTCIDCallBlkProfile 1 }

pktcRSTCIDCBlkErrTone OBJECT-TYPE
    SYNTAX      PktcRSTTONEANNC
    MAX-ACCESS  read-write
    STATUS      current
    DESCRIPTION
        "PACM-ACCESS:NW:RO:MA
        This data element specifies the error tone after
        vertical feature code failure."
REFERENCE "PacketCable Residential SIP Telephony Feature Specification"
 ::= { pktcRSTCIDCallBlkProfile 2 }

eXTOBJpktcRSTCIDCallBlkProfile OBJECT-TYPE
    SYNTAX      PktcPACMExtension
    MAX-ACCESS  read-only
    STATUS      current
    DESCRIPTION
        "PACM-ACCESS:NW:RW:OP
        Extension object for 'pktcRSTCIDCallBlkProfile'."
 ::= { pktcRSTCIDCallBlkProfile 3 }

-----
-- Pktc PACM RST Caller ID Per Call Delivery Feature Profile
-- Ref (PacketCable RST specification): "Caller ID Per-Call Delivery Feature
Data"
-----
pktcRSTCIDCallDelProfile OBJECT IDENTIFIER ::= { pktcPACMRSTProfile 10 }

pktcRSTCIDCDelConfTone OBJECT-TYPE
    SYNTAX      PktcRSTTONEANNC
    MAX-ACCESS  read-write
    STATUS      current
    DESCRIPTION
        "PACM-ACCESS:NW:RO:MA
        This data element specifies the confirmation tone after
        vertical feature code."
REFERENCE "PacketCable Residential SIP Telephony Feature Specification"
 ::= { pktcRSTCIDCallDelProfile 1 }

pktcRSTCIDCDelErrTone OBJECT-TYPE
    SYNTAX      PktcRSTTONEANNC
    MAX-ACCESS  read-write
    STATUS      current
    DESCRIPTION
        "PACM-ACCESS:NW:RO:MA
        This data element specifies the error tone after
        vertical feature code failure."
REFERENCE "PacketCable Residential SIP Telephony Feature Specification"
 ::= { pktcRSTCIDCallDelProfile 2 }

eXTOBJpktcRSTCIDCallDelProfile OBJECT-TYPE
    SYNTAX      PktcPACMExtension
    MAX-ACCESS  read-only
    STATUS      current
    DESCRIPTION
        "PACM-ACCESS:NW:RW:OP
        Extension object for 'pktcRSTCIDCallDelProfile'."
 ::= { pktcRSTCIDCallDelProfile 3 }

-----
-- Pktc PACM RST Call Forwarding Variable Feature Profile
-- Ref (PacketCable RST specification): "Call Forwarding Variable Feature Data"
-----
pktcRSTCFwdProfile OBJECT IDENTIFIER ::= { pktcPACMRSTProfile 11 }

```

```
pktcRSTCFwdSpDialTone OBJECT-TYPE
    SYNTAX      TruthValue
    MAX-ACCESS  read-write
    STATUS      current
    DESCRIPTION
        "PACM-ACCESS:NW:RO:MA
        This data element specifies the special conditions dial tone
        when forwarded indicator."
    REFERENCE  "PacketCable Residential SIP Telephony Feature Specification"
    ::= { pktcRSTCFwdProfile 1 }

pktcRSTCFwdSubDuration OBJECT-TYPE
    SYNTAX      Integer32
    MAX-ACCESS  read-write
    STATUS      current
    DESCRIPTION
        "PACM-ACCESS:NW:RO:MA
        This data element specifies the subscription duration in seconds."
    REFERENCE  "PacketCable Residential SIP Telephony Feature Specification"
    ::= { pktcRSTCFwdProfile 2 }

eXTOBJpktcRSTCFwdProfile OBJECT-TYPE
    SYNTAX      PktpacmExtension
    MAX-ACCESS  read-only
    STATUS      current
    DESCRIPTION
        "PACM-ACCESS:NW:RW:OP
        Extension object for 'pktcRSTCFwdProfile'."
    ::= { pktcRSTCFwdProfile 3 }

-----
-- Pktpacm RST Call Waiting Feature Data
-- Ref (PacketCable RST specification): "Call Waiting Feature Data"
-----
pktcRSTCallWaitProfile OBJECT IDENTIFIER ::= { pktpacmRSTProfile 12 }

pktcRSTCWDisableStarCode OBJECT-TYPE
    SYNTAX      PktpacmRSTDigitMap
    MAX-ACCESS  read-write
    STATUS      current
    DESCRIPTION
        "PACM-ACCESS:NW:RO:MA
        This data element specifies the per call call-waiting
        disable star code."
    REFERENCE  "PacketCable Residential SIP Telephony Feature Specification"
    ::= { pktcRSTCallWaitProfile 1 }

eXTOBJpktcRSTCallWaitProfile OBJECT-TYPE
    SYNTAX      PktpacmExtension
    MAX-ACCESS  read-only
    STATUS      current
    DESCRIPTION
        "PACM-ACCESS:NW:RW:OP
        Extension object for 'pktcRSTCallWaitProfile'."
    ::= { pktcRSTCallWaitProfile 2 }

-----
-- Pktpacm RST Call Hold Feature Profile
-- Ref (PacketCable RST specification): "Call Hold Feature Data"
-----
pktcRSTCallHoldProfile OBJECT IDENTIFIER ::= { pktpacmRSTProfile 13 }

pktcRSTCHFeatCode OBJECT-TYPE
    SYNTAX      SnmpAdminString
    MAX-ACCESS  read-write
    STATUS      current
    DESCRIPTION
```

```

    "PACM-ACCESS:NW:RO:MA
    This data element specifies the Call Hold Feature Code."
REFERENCE "PacketCable Residential SIP Telephony Feature Specification"
 ::= { pktcRSTCallHoldProfile 1 }

pktcRSTCHFeatConfirm OBJECT-TYPE
SYNTAX      PktcRSTTONEANNC
MAX-ACCESS  read-write
STATUS      current
DESCRIPTION
    "PACM-ACCESS:NW:RO:MA
    This data element specifies the feature activation/deactivation
    confirmation indicator."
REFERENCE "PacketCable Residential SIP Telephony Feature Specification"
 ::= { pktcRSTCallHoldProfile 2 }

exTOBJpktcRSTCallHoldProfile OBJECT-TYPE
SYNTAX      PktcPACMExtension
MAX-ACCESS  read-only
STATUS      current
DESCRIPTION
    "PACM-ACCESS:NW:RW:OP
    Extension object for 'pktcRSTCallHoldProfile'."
 ::= { pktcRSTCallHoldProfile 3 }
-----
-- Pktc PACM RST Call Transfer Feature Profile
-- Ref (PacketCable RST specification): "Call Transfer Feature Data"
-----
pktcRSTCallTransProfile OBJECT IDENTIFIER ::= { pktcPACMRSTProfile 14 }

pktcRSTCTNotifyTimeout OBJECT-TYPE
SYNTAX      Integer32
MAX-ACCESS  read-write
STATUS      current
DESCRIPTION
    "PACM-ACCESS:NW:RO:MA
    This data element specifies the Notify
    Timeout in seconds."
REFERENCE "PacketCable Residential SIP Telephony Feature Specification"
 ::= { pktcRSTCallTransProfile 1 }

exTOBJpktcRSTCallTransProfile OBJECT-TYPE
SYNTAX      PktcPACMExtension
MAX-ACCESS  read-only
STATUS      current
DESCRIPTION
    "PACM-ACCESS:NW:RW:OP
    Extension object for 'pktcRSTCallTransProfile'."
 ::= { pktcRSTCallTransProfile 2 }
-----
-- Pktc 3WC Feature Data
-- Ref (PacketCable RST specification): "3WC Feature Data"
-----
pktcRST3WCFeatureProfile OBJECT IDENTIFIER ::= { pktcPACMRSTProfile 15 }

exTOBJpktcRST3WCFeatureProfile OBJECT-TYPE
SYNTAX      PktcPACMExtension
MAX-ACCESS  read-only
STATUS      current
DESCRIPTION
    "PACM-ACCESS:NW:RW:OP
    Extension object for 'pktcRST3WCFeatureProfile'."
 ::= { pktcRST3WCFeatureProfile 1 }
-----

```

```
-- Pktc PACM RST Do Not Disturb Feature Profile
-- Ref (PacketCable RST specification): "DND Feature Data"
-----
pktcRSTDNDProfile OBJECT IDENTIFIER ::= { pktcPACMRSTProfile 16 }

pktcRSTDNDActConfirm OBJECT-TYPE
    SYNTAX      PktcRSTTONEANNC
    MAX-ACCESS  read-write
    STATUS      current
    DESCRIPTION
        "PACM-ACCESS:NW:RO:MA
        This data element specifies the Feature Activation Confirmation
        Indicator."
    REFERENCE  "PacketCable Residential SIP Telephony Feature Specification"
    ::= { pktcRSTDNDProfile 1 }

pktcRSTDNDDeActConfirm OBJECT-TYPE
    SYNTAX      PktcRSTTONEANNC
    MAX-ACCESS  read-write
    STATUS      current
    DESCRIPTION
        "PACM-ACCESS:NW:RO:MA
        This data element specifies the Feature Deactivation Confirmation
        Indicator."
    REFERENCE  "PacketCable Residential SIP Telephony Feature Specification"
    ::= { pktcRSTDNDProfile 2 }

eXTOBJpktcRSTDNDProfile OBJECT-TYPE
    SYNTAX      PktcPACMExtension
    MAX-ACCESS  read-only
    STATUS      current
    DESCRIPTION
        "PACM-ACCESS:NW:RW:OP
        Extension object for 'pktcRSTDNDProfile'."
    ::= { pktcRSTDNDProfile 3 }

-----
-- Pktc PACM RST Subscriber Programmable PIN Feature Data
-- Ref (PacketCable RST specification): "Subscriber Programmable PIN Feature
Data"
-----
pktcRSTSubProgPINProfile OBJECT IDENTIFIER ::= { pktcPACMRSTProfile 17 }

eXTOBJpktcRSTSubProgPINProfile OBJECT-TYPE
    SYNTAX      PktcPACMExtension
    MAX-ACCESS  read-only
    STATUS      current
    DESCRIPTION
        "PACM-ACCESS:NW:RW:OP
        Extension object for 'pktcRSTSubProgPINProfile'."
    ::= { pktcRSTSubProgPINProfile 1 }

-----
-- Pktc PACM RST MWI Feature Profile
-- Ref (PacketCable RST specification): "MWI Feature Data"
-----
pktcRSTMWIPProfile OBJECT IDENTIFIER ::= { pktcPACMRSTProfile 18 }

pktcRSTSubDuration OBJECT-TYPE
    SYNTAX      Integer32
    MAX-ACCESS  read-write
    STATUS      current
    DESCRIPTION
        "PACM-ACCESS:NW:RW:MA
        This data element specifies the MWI Subscription duration."
    REFERENCE  "PacketCable Residential SIP Telephony Feature Specification"
```

```

 ::= { pktcRSTMWIPProfile 1 }

EXTOBJpktcRSTMWIPProfile OBJECT-TYPE
    SYNTAX      PktcPACMExtension
    MAX-ACCESS  read-only
    STATUS      current
    DESCRIPTION
        "PACM-ACCESS:NW:RW:OP
         Extension object for 'pktcRSTMWIPProfile'."
 ::= { pktcRSTMWIPProfile 2 }

-----
-- Pktc PACM RST Auto Recall Feature Profile
-- Ref (PacketCable RST specification): "Auto Recall Feature Data"
-----
pktcRSTAutoRecallProfile OBJECT IDENTIFIER ::= { pktcPACMRSTProfile 19 }

pktcRSTARTimer OBJECT-TYPE
    SYNTAX      Integer32 (0..30)
    MAX-ACCESS  read-write
    STATUS      current
    DESCRIPTION
        "PACM-ACCESS:NW:RO:MA
         This data element specifies the auto recall timer.
         This is minutes of feature duration."
    REFERENCE  "PacketCable Residential SIP Telephony Feature Specification"
    DEFVAL     {30}
 ::= { pktcRSTAutoRecallProfile 1 }

pktcRSTARSpRingDuration OBJECT-TYPE
    SYNTAX      Integer32
    MAX-ACCESS  read-write
    STATUS      current
    DESCRIPTION
        "PACM-ACCESS:NW:RO:MA
         This data element specifies the auto recall special ring duration.
         This is the number of special ringing ring cycles."
    REFERENCE  "PacketCable Residential SIP Telephony Feature Specification"
 ::= { pktcRSTAutoRecallProfile 2 }

pktcRSTARSpRingRetryTime OBJECT-TYPE
    SYNTAX      Integer32
    MAX-ACCESS  read-write
    STATUS      current
    DESCRIPTION
        "PACM-ACCESS:NW:RO:MA
         This data element specifies the auto recall special ringing retry
         wait interval. This is seconds to wait between attempts to alert
         the user with special ringing."
    REFERENCE  "PacketCable Residential SIP Telephony Feature Specification"
 ::= { pktcRSTAutoRecallProfile 3 }

pktcRSTARSpRingRetries OBJECT-TYPE
    SYNTAX      Integer32
    MAX-ACCESS  read-write
    STATUS      current
    DESCRIPTION
        "PACM-ACCESS:NW:RO:MA
         This data element specifies the number of auto recall special ringing
         retries.
         This is the number of times to retry special ringing before canceling
         the AR request."
    REFERENCE  "PacketCable Residential SIP Telephony Feature Specification"
 ::= { pktcRSTAutoRecallProfile 4 }

pktcRSTARMaxSubSend OBJECT-TYPE
    SYNTAX      Integer32

```

```

MAX-ACCESS read-write
STATUS current
DESCRIPTION
  "PACM-ACCESS:NW:RO:MA
  This data element specifies the maximum number of simultaneous
  subscribes the UE should send."
REFERENCE "PacketCable Residential SIP Telephony Feature Specification"
 ::= { pktcRSTAutoRecallProfile 5 }

pktcRSTARMaxSubRec OBJECT-TYPE
SYNTAX Integer32
MAX-ACCESS read-write
STATUS current
DESCRIPTION
  "PACM-ACCESS:NW:RO:MA
  This data element specifies the maximum number of simultaneous
  subscriptions the UE should honor."
REFERENCE "PacketCable Residential SIP Telephony Feature Specification"
 ::= { pktcRSTAutoRecallProfile 6 }

eXTOBJpktcRSTAutoRecallProfile OBJECT-TYPE
SYNTAX PktcPACMExtension
MAX-ACCESS read-only
STATUS current
DESCRIPTION
  "PACM-ACCESS:NW:RW:OP
  Extension object for 'pktcRSTAutoRecallProfile'."
 ::= { pktcRSTAutoRecallProfile 7 }

-----
-- Pktc PACM RST Auto Callback Feature Profile
-- Ref (PacketCable RST specification): "Auto Callback Feature Data"
-----
pktcRSTAutoCallbackProfile OBJECT IDENTIFIER ::= { pktcPACMRSTProfile 20 }

pktcRSTACbTimer OBJECT-TYPE
SYNTAX Integer32 (0..30)
MAX-ACCESS read-write
STATUS current
DESCRIPTION
  "PACM-ACCESS:NW:RO:MA
  This data element specifies the auto callback timer.
  This is minutes of feature duration. 0-30min. Default=30"
REFERENCE "PacketCable Residential SIP Telephony Feature Specification"
DEFVAL {30}
 ::= { pktcRSTAutoCallbackProfile 1 }

pktcRSTACbSpRingDuration OBJECT-TYPE
SYNTAX Integer32
MAX-ACCESS read-write
STATUS current
DESCRIPTION
  "PACM-ACCESS:NW:RO:MA
  This data element specifies the auto callback special ring duration.
  This is the number of special ringing ring cycles."
REFERENCE "PacketCable Residential SIP Telephony Feature Specification"
 ::= { pktcRSTAutoCallbackProfile 2 }

pktcRSTACbSpRingRetryTime OBJECT-TYPE
SYNTAX Integer32
MAX-ACCESS read-write
STATUS current
DESCRIPTION
  "PACM-ACCESS:NW:RO:MA
  This data element specifies the auto callback special ringing retry
  wait interval. This is seconds to wait between attempts to alert
  the user with special ringing."

```

```

REFERENCE "PacketCable Residential SIP Telephony Feature Specification"
 ::= { pktcRSTAutoCallbackProfile 3 }

pktcRSTACbSpRingRetries OBJECT-TYPE
    SYNTAX      Integer32
    MAX-ACCESS  read-write
    STATUS      current
    DESCRIPTION
        "PACM-ACCESS:NW:RO:MA
        This data element specifies the number of auto callback special ringing
retries.
        This is the number of times to retry special ringing before canceling
the AR request."
    REFERENCE "PacketCable Residential SIP Telephony Feature Specification"
 ::= { pktcRSTAutoCallbackProfile 4 }

pktcRSTACbMaxSubSend OBJECT-TYPE
    SYNTAX      Integer32
    MAX-ACCESS  read-write
    STATUS      current
    DESCRIPTION
        "PACM-ACCESS:NW:RO:MA
        This data element specifies the maximum number of simultaneous
subscribes the UE should send.."
    REFERENCE "PacketCable Residential SIP Telephony Feature Specification"
 ::= { pktcRSTAutoCallbackProfile 5 }

pktcRSTACbMaxSubRec OBJECT-TYPE
    SYNTAX      Integer32
    MAX-ACCESS  read-write
    STATUS      current
    DESCRIPTION
        "PACM-ACCESS:NW:RO:MA
        This data element specifies the maximum number of simultaneous
subscriptions
the UE should honor."
    REFERENCE "PacketCable Residential SIP Telephony Feature Specification"
 ::= { pktcRSTAutoCallbackProfile 6 }

exTOBJpktcRSTAutoCallbackProfile OBJECT-TYPE
    SYNTAX      PktcPACMExtension
    MAX-ACCESS  read-only
    STATUS      current
    DESCRIPTION
        "PACM-ACCESS:NW:RW:OP
        Extension object for 'pktcRSTAutoCallbackProfile'."
 ::= { pktcRSTAutoCallbackProfile 7 }

-----
-- Pktc PACM RST Busy Line Verify Feature Profile
-- Ref (PacketCable RST specification): "Busy Line Verify Feature Data"
-----
pktcRSTBusyLineProfile OBJECT IDENTIFIER ::= { pktcPACMRSTProfile 21 }

pktcRSTBusyLineVOperId OBJECT-TYPE
    SYNTAX      SnmpAdminString
    MAX-ACCESS  read-write
    STATUS      current
    DESCRIPTION
        "PACM-ACCESS:NW:RO:MA
        This data element specifies the Busy Line Verify Operator Id."
    REFERENCE "PacketCable Residential SIP Telephony Feature Specification"
 ::= { pktcRSTBusyLineProfile 1 }

exTOBJpktcRSTBusyLineProfile OBJECT-TYPE
    SYNTAX      PktcPACMExtension
    MAX-ACCESS  read-only

```

```
STATUS      current
DESCRIPTION
  "PACM-ACCESS:NW:RW:OP
  Extension object for 'pktcRSTBusyLineProfile'."
 ::= { pktcRSTBusyLineProfile 2 }

-----
-- Pktc PACM RST Emergency Services Feature Profile
-- Ref (PacketCable RST specification): "Emergency Services Feature Data"
-----
pktcRSTEmSvcProfile OBJECT IDENTIFIER ::= { pktcPACMRSTProfile 22 }

pktcRSTEmSvcNwHoldTimer OBJECT-TYPE
SYNTAX      Integer32
MAX-ACCESS  read-write
STATUS      current
DESCRIPTION
  "PACM-ACCESS:NW:RO:MA
  This data element specifies the Emergency Services network hold
  timer in minutes."
REFERENCE   "PacketCable Residential SIP Telephony Feature Specification"
DEFVAL     {45}
 ::= { pktcRSTEmSvcProfile 1 }

pktcRSTEmSvcHowlTimer OBJECT-TYPE
SYNTAX      Integer32
MAX-ACCESS  read-write
STATUS      current
DESCRIPTION
  "PACM-ACCESS:NW:RO:MA
  This data element specifies the Emergency Services howler
  timer in seconds. "
REFERENCE   "PacketCable Residential SIP Telephony Feature Specification"
DEFVAL     {3}
 ::= { pktcRSTEmSvcProfile 2 }

pktcRSTEmSvcMediaDSCPVal OBJECT-TYPE
SYNTAX      Integer32 (0..63)
MAX-ACCESS  read-write
STATUS      current
DESCRIPTION
  "PACM-ACCESS:NW:RO:MA
  This data element specifies the Emergency Services emergency media
  DSCP value."
REFERENCE   "PacketCable Residential SIP Telephony Feature Specification"
 ::= { pktcRSTEmSvcProfile 3 }

eXTOBJpktcRSTEmSvcProfile OBJECT-TYPE
SYNTAX      PktcPACMExtension
MAX-ACCESS  read-only
STATUS      current
DESCRIPTION
  "PACM-ACCESS:NW:RW:OP
  Extension object for 'pktcRSTEmSvcProfile'."
 ::= { pktcRSTEmSvcProfile 4 }

-----
-- Conformance Information
-----
pktcRSTMIBCompliances OBJECT IDENTIFIER ::= { pktcPACMRSTConformance 1 }
pktcRSTMIBGroups      OBJECT IDENTIFIER ::= { pktcPACMRSTConformance 2 }

-- Compliance Statements
pktcRSTMIBCompliance MODULE-COMPLIANCE
STATUS      current
DESCRIPTION
  "The compliance statement for implementations of the RST Mib "
```

```

MODULE -- this module
MANDATORY-GROUPS {
    pktcRSTBasicCallGroup,
    pktcRSTAncGroup,
    pktcRSTUEStGroup,
    pktcRSTNoAnsGroup,
    pktcRSTCallerIDGroup,
    pktcRSTCallFwdGroup,
    pktcRSTCallWaitGroup,
    pktcRSTCallHoldGroup,
    pktcRSTCallTransGroup,
    pktcRSTDNDGroup,
    pktcRSTMWIGroup,
    pktcRSTAutoRecallGroup,
    pktcRSTAutoCallbackGroup,
    pktcRSTBusyLineGroup,
    pktcRSTEmerSvcGroup
}
 ::= { pktcRSTMIBCompliances 1 }

pktcRSTBasicCallGroup OBJECT-GROUP
OBJECTS {
    pktcRSTBasicCallDigitMap,
    pktcRSTBasicCallSDP,
    pktcRSTBasicCallByeDelay,
    pktcRSTBasicCallOrigDTimer,
    pktcRSTBasicCallTermOHErrSignal,
    pktcRSTBasicCallTermErrSignalTimer,
    pktcRSTBasicCallPermSeqTone1,
    pktcRSTBasicCallPermSeqTimer1,
    pktcRSTBasicCallPermSeqTone2,
    pktcRSTBasicCallPermSeqTimer2,
    pktcRSTBasicCallPermSeqTone3,
    pktcRSTBasicCallPermSeqTimer3,
    pktcRSTBasicCallLORTimer
}
STATUS current
DESCRIPTION
    "The RST Basic Call Group."
 ::= { pktcRSTMIBGroups 1}

pktcRSTAncGroup OBJECT-GROUP
OBJECTS {
    pktcRSTAncRes,
    pktcRSTAncDomain,
    pktcRSTAncPath,
    pktcRSTAncMIMEType,
    pktcRSTAncURI,
    pktcRSTAncMediaURI,
    pktcRSTAncMediaCachMaxAge,
    pktcRSTLocalMediaType,
    pktcRSTLocalMediaData,
    pktcRSTAncLangPrefLang
}
STATUS current
DESCRIPTION
    "The RST Announcement Group."
 ::= { pktcRSTMIBGroups 2}

pktcRSTUEStGroup OBJECT-GROUP
OBJECTS {
    pktcRSTUEStRegExp
}
STATUS current
DESCRIPTION
    "The RST UE Status Change Group."
 ::= { pktcRSTMIBGroups 3}

```

```
pktrSTNoAnsGroup OBJECT-GROUP
  OBJECTS {
    pktrSTNAnsTODuration
  }
  STATUS current
  DESCRIPTION
    "The RST No Answer Timeout Group."
  ::= { pktrSTMIBGroups 4}

pktrSTCallerIDGroup OBJECT-GROUP
  OBJECTS {
    pktrSTCIDPPS,
    -- CID per Blocking
    pktrSTCIDCBlkConfTone,
    pktrSTCIDCBlkErrTone,
    -- CID per Delivery
    pktrSTCIDCDelConfTone,
    pktrSTCIDCDelErrTone
  }
  STATUS current
  DESCRIPTION
    "The RST Caller ID Group."
  ::= { pktrSTMIBGroups 5}

pktrSTCIDDisplayGroup OBJECT-GROUP
  OBJECTS {
    pktrSTCIDCNDActStatus,
    pktrSTCIDCNAMDActStatus,
    pktrSTCIDDispDefCountry,
    pktrSTCIDDispTimeAdj
  }
  STATUS current
  DESCRIPTION
    "The RST Caller ID Display Group."
  ::= { pktrSTMIBGroups 6}

pktrSTCallFwdGroup OBJECT-GROUP
  OBJECTS {
    pktrSTCFwdSpDialTone,
    pktrSTCFwdSubDuration
  }
  STATUS current
  DESCRIPTION
    "The RST Call Forward Group."
  ::= { pktrSTMIBGroups 7}

pktrSTCallWaitGroup OBJECT-GROUP
  OBJECTS {
    pktrSTCWDisableStarCode
  }
  STATUS current
  DESCRIPTION
    "The RST Call Waiting Group."
  ::= { pktrSTMIBGroups 8}

pktrSTCallHoldGroup OBJECT-GROUP
  OBJECTS {
    pktrSTCHFeatCode,
    pktrSTCHFeatConfirm
  }
  STATUS current
  DESCRIPTION
    "The RST Call Hold Group."
  ::= { pktrSTMIBGroups 9}

pktrSTCallTransGroup OBJECT-GROUP
```

```

OBJECTS {
    pktcRSTCTNotifyTimeout
}
STATUS current
DESCRIPTION
    "The RST Call Transfer Group."
::= { pktcRSTMIBGroups 10}

pktcRSTDNDGroup OBJECT-GROUP
OBJECTS {
    pktcRSTDNDActConfirm,
    pktcRSTDNDDeActConfirm
}
STATUS current
DESCRIPTION
    "The RST Do Not Disturb Group."
::= { pktcRSTMIBGroups 11}

pktcRSTMWIGroup OBJECT-GROUP
OBJECTS {
    pktcRSTSubDuration
}
STATUS current
DESCRIPTION
    "The RST MWI Group."
::= { pktcRSTMIBGroups 12}

pktcRSTAutoRecallGroup OBJECT-GROUP
OBJECTS {
    pktcRSTARTimer,
    pktcRSTARSpRingDuration,
    pktcRSTARSpRingRetryTime,
    pktcRSTARSpRingRetries,
    pktcRSTARMaxSubSend,
    pktcRSTARMaxSubRec
}
STATUS current
DESCRIPTION
    "The RST Auto Recall Group."
::= { pktcRSTMIBGroups 13}

pktcRSTAutoCallbackGroup OBJECT-GROUP
OBJECTS {
    pktcRSTACbTimer,
    pktcRSTACbSpRingDuration,
    pktcRSTACbSpRingRetryTime,
    pktcRSTACbSpRingRetries,
    pktcRSTACbMaxSubSend,
    pktcRSTACbMaxSubRec
}
STATUS current
DESCRIPTION
    "The RST Auto Callback Group."
::= { pktcRSTMIBGroups 14}

pktcRSTBusyLineGroup OBJECT-GROUP
OBJECTS {
    pktcRSTBusyLineVOperId
}
STATUS current
DESCRIPTION
    "The RST Busy Line Verify Group."
::= { pktcRSTMIBGroups 15}

pktcRSTEmerSvcGroup OBJECT-GROUP
OBJECTS {
    pktcRSTEmSvcNwHoldTimer,

```

```
        pktcRSTEmSvcHowlTimer,
        pktcRSTEmSvcMediaDSCPVal
    }
    STATUS current
    DESCRIPTION
        "The RST Emergency Services Group."
    ::= { pktcRSTMIBGroups 16}

pktcRSTeXTObJS OBJECT-GROUP
    OBJECTS {
        pktcPACMRSTMinorVersion,
        eXTObJpktcRSTObjects,
        eXTObJpktcRSTBasicCallFeatProfile,
        eXTObJpktcRSTAncFeatProfile,
        eXTObJpktcRSTAncMapEntry,
        eXTObJpktcRSTAncMediaMapEntry,
        eXTObJpktcRSTLocalMediaProfile,
        eXTObJpktcRSTLocalMediaEntry,
        eXTObJpktcRSTAncLangProfile,
        eXTObJpktcRSTUEStatusChangeProfile,
        eXTObJpktcRSTNoAnsTimeoutProfile,
        eXTObJpktcRSTCallerIdProfile,
        eXTObJpktcRSTCIDDisplayProfile,
        eXTObJpktcRSTCIDCallBlkProfile,
        eXTObJpktcRSTCIDCallDelProfile,
        eXTObJpktcRSTCFwdProfile,
        eXTObJpktcRSTCallWaitProfile,
        eXTObJpktcRSTCallHoldProfile,
        eXTObJpktcRSTCallTransProfile,
        eXTObJpktcRST3WCFeatureProfile,
        eXTObJpktcRSTDNDProfile,
        eXTObJpktcRSTSubProgPINProfile,
        eXTObJpktcRSTMWIProfile,
        eXTObJpktcRSTAutoRecallProfile,
        eXTObJpktcRSTAutoCallbackProfile,
        eXTObJpktcRSTBusyLineProfile,
        eXTObJpktcRSTEmSvcProfile
    }
    STATUS current
    DESCRIPTION
        "The RST Extension Objects Group."
    ::= { pktcRSTMIBGroups 17}

END
```

## I.2 SMI representation of the RST E-DVA Profile

```
CL-PKTC-RST-EDVA DEFINITIONS ::= BEGIN

IMPORTS
    MODULE-IDENTITY,
    OBJECT-TYPE,
    Integer32
        FROM SNMPv2-SMI
    OBJECT-GROUP,
    MODULE-COMPLIANCE
        FROM SNMPv2-CONF
    TruthValue
        FROM SNMPv2-TC
    InetAddress,
    InetAddressType
        FROM INET-ADDRESS-MIB
    PktcPACMExtension
        FROM CL-PKTC-TC
    pktcPACMMibs
        FROM CLAB-DEF-MIB;
```

```

pktcPACMRSTEDVAMib MODULE-IDENTITY
  LAST-UPDATED "0609270000Z"
  ORGANIZATION "Cable Television Laboratories, Inc."
  CONTACT-INFO
    "Cable Television Laboratories, Inc.
     858 Coal Creek Circle,
     Louisville, CO 80027, USA
     +1 303-661-3307
     mibs@cablelabs.com"

  DESCRIPTION
    "This MIB module contains configuration MIB
     objects for the RST Service Embedded Digital
     Voice Adaptor (E-DVA). The objects are referenced
     in the PacketCable Residential SIP Telephony (RST)
     E-DVA specification."
    ::= { pktcPACMMibs 5 }

-- Administrative assignments
pktcPACMRSTEDVANotification      OBJECT IDENTIFIER ::= { pktcPACMRSTEDVAMib 0 }
pktcPACMRSTEDVAObjects          OBJECT IDENTIFIER ::= { pktcPACMRSTEDVAMib 1 }
pktcPACMRSTEDVAConformance      OBJECT IDENTIFIER ::= { pktcPACMRSTEDVAMib 2 }

pktcPACMRSTEDVACompliances      OBJECT IDENTIFIER ::= {
pktcPACMRSTEDVAConformance 1 }
pktcPACMRSTEDVAGroups          OBJECT IDENTIFIER ::= {
pktcPACMRSTEDVAConformance 2 }

-----
-- Minor version
-----
pktcPACMRSTEDVAMinorVersion OBJECT-TYPE
  SYNTAX      Integer32
  MAX-ACCESS  read-only
  STATUS      current
  DESCRIPTION
    "PACM-ACCESS:NW:R0:MA
     The default value of this MIB Object contains the minor version
     of the data model."
  DEFVAL {0}
  ::= { pktcPACMRSTEDVAObjects 1 }

-----
-- MIB Objects
-----
pktcPACMRSTEDVAProfileIDs      OBJECT IDENTIFIER ::= { pktcPACMRSTEDVAObjects
2 }
pktcPACMRSTEDVAProfile        OBJECT IDENTIFIER ::= { pktcPACMRSTEDVAObjects
3 }

-----
-- Extension Object
-----
eXTOBJpktcPACMRSTEDVAObjects OBJECT-TYPE
  SYNTAX      PktcPACMEExtension
  MAX-ACCESS  read-only
  STATUS      current
  DESCRIPTION
    "PACM-ACCESS:NW:RW:OP
     Extension object for 'pktcPACMRSTEDVAObjects'."
  ::= { pktcPACMRSTEDVAObjects 4 }

-----
-- Pktc Line Number MIB Object
-----
pktcRSTEDVALineNumber OBJECT-TYPE
  SYNTAX      Integer32 (1..10)

```

```

MAX-ACCESS not-accessible
STATUS current
DESCRIPTION
  "PACM-ACCESS:AW:RO:CM
  This data element MUST identify a Line Number on an E-DVA"
REFERENCE "PacketCable Residential SIP Telephony E-DVA Specification"
 ::= { pktcPACMRSTEDVAProfileIDs 1 }

eXTOBJpktcPACMRSTEDVAProfileIDs OBJECT-TYPE
SYNTAX PktcPACMExtension
MAX-ACCESS read-only
STATUS current
DESCRIPTION
  "PACM-ACCESS:NW:RW:OP
  Extension object for 'pktcPACMRSTEDVAProfileIDs'."
 ::= { pktcPACMRSTEDVAProfileIDs 2 }

-----
-- E-DVA Network Disconnect Signaling Event
-- Ref (PacketCable RST E-DVA Specification): Network Disconnect Signaling Event
-----
pktcRSTEDVANetDiscProfile OBJECT IDENTIFIER ::= { pktcPACMRSTEDVAProfile 1 }

-- The Network Disconnect Signaling Event Table
pktcRSTEDVANetDiscTable OBJECT-TYPE
SYNTAX SEQUENCE OF PktcRSTEDVANetDiscTableEntry
MAX-ACCESS not-accessible
STATUS current
DESCRIPTION
  "PACM-ACCESS:NW:RO:MA
  This data table represents the Network Disconnect time
  for each line provided by the E-DVA."
 ::= { pktcRSTEDVANetDiscProfile 1 }

pktcRSTEDVANetDiscTableEntry OBJECT-TYPE
SYNTAX PktcRSTEDVANetDiscTableEntry
MAX-ACCESS not-accessible
STATUS current
DESCRIPTION
  "PACM-ACCESS:NW:RO:MA
  Each entry in this data table describes the Network Disconnect
  Time for the associated line."
INDEX { pktcRSTEDVAVLineNumber }
 ::= { pktcRSTEDVANetDiscTable 1 }

PktcRSTEDVANetDiscTableEntry ::=
SEQUENCE {
    pktcRSTEDVANetDisc Integer32,
    eXTOBJpktcRSTEDVANetDiscTableEntry PktcPACMExtension
}

pktcRSTEDVANetDisc OBJECT-TYPE
SYNTAX Integer32 (0..2000)
MAX-ACCESS read-write
STATUS current
DESCRIPTION
  "PACM-ACCESS:NW:RO:MA
  This data element specifies the time in mSec that the E-DVA
  must remove DC bias when a call has been cleared by the network.

  A value of zero (0) indicates that the E-DVA MUST NOT remove DC bias
  when a call disconnects. The E-DVA MUST implement this element per
  PKT-SP-RST-E-DVA Section 7.2.3"
REFERENCE "PacketCable Residential SIP Telephony E-DVA Specification"
DEFVAL {1000}
 ::= { pktcRSTEDVANetDiscTableEntry 1 }

```

```

eXTOBJpktcRSTEDVANetDiscTableEntry OBJECT-TYPE
    SYNTAX      PktcPACMExtension
    MAX-ACCESS  read-only
    STATUS      current
    DESCRIPTION
        "PACM-ACCESS:NW:RW:OP
         Extension object for 'pktcRSTEDVANetDiscTableEntry'."
    ::= { pktcRSTEDVANetDiscTableEntry 2 }

eXTOBJpktcRSTEDVANetDiscProfile OBJECT-TYPE
    SYNTAX      PktcPACMExtension
    MAX-ACCESS  read-only
    STATUS      current
    DESCRIPTION
        "PACM-ACCESS:NW:RW:OP
         Extension object for 'pktcRSTEDVANetDiscProfile'."
    ::= { pktcRSTEDVANetDiscProfile 2 }
-----
-- E-DVA Answer Supervision Event
-- Ref (PacketCable RST E-DVA Specification): Answer Supervision Event
-----
pktcRSTEDVAAnsSupProfile OBJECT IDENTIFIER ::= { pktcPACMRSTEDVAProfile 2 }

-- The Answer Supervision Signal Event Table
pktcRSTEDVAAnsSupTable OBJECT-TYPE
    SYNTAX      SEQUENCE OF PktcRSTEDVAAnsSupTableEntry
    MAX-ACCESS  not-accessible
    STATUS      current
    DESCRIPTION
        "PACM-ACCESS:NW:RO:MA
         This data table represents the Answer Supervision
         for each line provided by the E-DVA."
    ::= { pktcRSTEDVAAnsSupProfile 1 }

pktcRSTEDVAAnsSupTableEntry OBJECT-TYPE
    SYNTAX      PktcRSTEDVAAnsSupTableEntry
    MAX-ACCESS  not-accessible
    STATUS      current
    DESCRIPTION
        "PACM-ACCESS:NW:RO:MA
         Each entry in this data table describes the Answer Supervision
         for the associated line."
    INDEX { pktcRSTEDVALineNumber }
    ::= { pktcRSTEDVAAnsSupTable 1 }

PktcRSTEDVAAnsSupTableEntry ::=
    SEQUENCE {
        pktcRSTEDVAAnsSup          TruthValue,
        eXTOBJpktcRSTEDVAAnsSupTableEntry PktcPACMExtension
    }

pktcRSTEDVAAnsSup OBJECT-TYPE
    SYNTAX      TruthValue
    MAX-ACCESS  read-write
    STATUS      current
    DESCRIPTION
        "PACM-ACCESS:NW:RO:MA
         This data element specifies the Answer Supervision state.
         Answer Supervision (also called battery reversal, reverse DC bias,
         or Reverse Loop Current Feed) is signaled when the distant end
         answers a call originated by the CPE. Typically this signal is
         used to notify electronic equipment such as PBXs which have a local
         billing system that a call has been answered. When provisioned to do
         so, the E-DVA may reverse DC bias when a call has been answered.

         The default value for this object is 'false' indicating that
         Answer Supervision is disabled (off).

```

```

        The E-DVA MUST implement this element per the PacketCable Residential
        SIP Telephony E-DVA Specification."
REFERENCE "PacketCable Residential SIP Telephony E-DVA Specification"
DEFVAL {false}
 ::= { pktcRSTEDVAAnsSupTableEntry 1 }

eXTOBJpktcRSTEDVAAnsSupTableEntry OBJECT-TYPE
SYNTAX      PktcPACMExtension
MAX-ACCESS  read-only
STATUS      current
DESCRIPTION
    "PACM-ACCESS:NW:RW:OP
     Extension object for 'EDVAAnsSupTableEntry'."
 ::= { pktcRSTEDVAAnsSupTableEntry 2 }

eXTOBJpktcRSTEDVAAnsSupProfile OBJECT-TYPE
SYNTAX      PktcPACMExtension
MAX-ACCESS  read-only
STATUS      current
DESCRIPTION
    "PACM-ACCESS:NW:RW:OP
     Extension object for 'pktcRSTEDVAAnsSupProfile'."
 ::= { pktcRSTEDVAAnsSupProfile 2 }

-----
-- E-DVA DTMF Relay Offer
-- Ref (PacketCable RST E-DVA Specification): DTMF Relay Offer
-----
pktcRSTEDVADtmfProfile OBJECT IDENTIFIER ::= { pktcPACMRSTEDVAProfile 3 }

pktcRSTEDVADtmfRelay OBJECT-TYPE
SYNTAX      TruthValue
MAX-ACCESS  read-write
STATUS      current
DESCRIPTION
    "PACM-ACCESS:NW:RO:MA
     This data table represents the DTMF Relay status
     for each line provided by the E-DVA.
     The E-DVA must support the use of DTMF for both dialed digits
     and for the relay of digits as part of an established session.
     When dialing the DTMF, signaling MUST be collected at the E-DVA.
     The digits are gathered according to the digit map and all digits
     are sent in a single message.

     If the value of this object is 'true' (on), the E-DVA must offer
     DTMF relay within SDP upon session origination.

     The E-DVA MUST implement this element per the PacketCable Residential
     SIP Telephony E-DVA Specification."
REFERENCE "PacketCable Residential SIP Telephony E-DVA Specification"
DEFVAL {true}
 ::= { pktcRSTEDVADtmfProfile 1 }

eXTOBJpktcRSTEDVADtmfProfile OBJECT-TYPE
SYNTAX      PktcPACMExtension
MAX-ACCESS  read-only
STATUS      current
DESCRIPTION
    "PACM-ACCESS:NW:RW:OP
     Extension object for 'pktcRSTEDVADtmfProfile'."
 ::= { pktcRSTEDVADtmfProfile 3 }

-----
-- E-DVA Provisioned Loss Plan
-- Ref (PacketCable RST E-DVA Specification): Provisioned Loss Plan
-----
```

```

pkcRSTEDVAPrLossProfile OBJECT IDENTIFIER ::= { pkcPACMRSTEDVAProfile 4 }

-- The Provisioned Loss Plan Table
pkcRSTEDVAPrLossTable OBJECT-TYPE
    SYNTAX      SEQUENCE OF PkcRSTEDVAPrLossTableEntry
    MAX-ACCESS  not-accessible
    STATUS      current
    DESCRIPTION
        "PACM-ACCESS:NW:RO:MA
        The DVA supports two provisioned loss parameters, one for
        the D/A direction (towards the subscriber) and one for A/D
        direction (from the subscriber) direction. This data table
        represents the loss for each line provided by the E-DVA."
    ::= { pkcRSTEDVAPrLossProfile 1 }

pkcRSTEDVAPrLossTableEntry OBJECT-TYPE
    SYNTAX      PkcRSTEDVAPrLossTableEntry
    MAX-ACCESS  not-accessible
    STATUS      current
    DESCRIPTION
        "PACM-ACCESS:NW:RO:MA
        The DVA supports two provisioned loss parameters, one for
        the D/A direction (towards the subscriber) and one for A/D
        direction (from the subscriber) direction. This data table
        represents the loss for each line provided by the E-DVA.

        Each entry in this data table describes the loss
        for the associated line."
    INDEX { pkcRSTEDVAPrLossTableEntry }
    ::= { pkcRSTEDVAPrLossTable 1 }

PkcRSTEDVAPrLossTableEntry ::=
    SEQUENCE {
        pkcRSTEDVAPrLossDA      Integer32,
        pkcRSTEDVAPrLossAD      Integer32,
        eXTObjPkcRSTEDVAPrLossTableEntry PkcPACMExtension
    }

pkcRSTEDVAPrLossDA OBJECT-TYPE
    SYNTAX      Integer32 (0..12)
    MAX-ACCESS  read-write
    STATUS      current
    DESCRIPTION
        "PACM-ACCESS:NW:RO:MA
        This data element specifies the provisioned loss parameter
        for the D/A direction (towards the subscriber) in dB.

        The E-DVA MUST implement this element per the PacketCable Residential
        SIP Telephony E-DVA Specification."
    REFERENCE  "PacketCable Residential SIP Telephony E-DVA Specification"
    DEFVAL {6}
    ::= { pkcRSTEDVAPrLossTableEntry 1 }

pkcRSTEDVAPrLossAD OBJECT-TYPE
    SYNTAX      Integer32 (0..12)
    MAX-ACCESS  read-write
    STATUS      current
    DESCRIPTION
        "PACM-ACCESS:NW:RO:MA
        This data element specifies the provisioned loss parameter
        for the A/D direction (from the subscriber)in dB.

        The E-DVA MUST implement this element per the PacketCable Residential
        SIP Telephony E-DVA Specification."
    REFERENCE  "PacketCable Residential SIP Telephony E-DVA Specification"
    DEFVAL {6}
    ::= { pkcRSTEDVAPrLossTableEntry 2 }

```

```

eXTOBJpktcRSTEDVAPrLossTableEntry OBJECT-TYPE
    SYNTAX      PktcPACMExtension
    MAX-ACCESS  read-only
    STATUS      current
    DESCRIPTION
        "PACM-ACCESS:NW:RW:OP
         Extension object for 'pktcRSTEDVAPrLossTableEntry'."
    ::= { pktcRSTEDVAPrLossTableEntry 3 }

eXTOBJpktcRSTEDVAPrLossProfile OBJECT-TYPE
    SYNTAX      PktcPACMExtension
    MAX-ACCESS  read-only
    STATUS      current
    DESCRIPTION
        "PACM-ACCESS:NW:RW:OP
         Extension object for 'pktcPACMRSTEDVAObjects'."
    ::= { pktcRSTEDVAPrLossProfile 2 }
-----
-- Network/E-DVA On Hook In/Out of Service
-- Ref (PacketCable RST E-DVA Specification): Network/E-DVA On Hook In/Out of
-- Service
-----
pktcRSTEDVADCBiasProfile OBJECT IDENTIFIER ::= { pktcPACMRSTEDVAProfile 5 }

-- The Network/E-DVA On Hook In/Out of Service Table
pktcRSTEDVADCBiasTable OBJECT-TYPE
    SYNTAX      SEQUENCE OF PktcRSTEDVADCBiasTableEntry
    MAX-ACCESS  not-accessible
    STATUS      current
    DESCRIPTION
        "PACM-ACCESS:NW:RO:MA
         DCbias is the signaling method to indicate the Network/E-DVA
         in/out of service state. The Operator is able to provision to
         enable planned, scheduled service times to not be signaled as
         an out of service state pending a maximum duration element.
         This data table represents the On Hook In/Out of Service parameters
         each line provided by the E-DVA."
    ::= { pktcRSTEDVADCBiasProfile 1 }

pktcRSTEDVADCBiasTableEntry OBJECT-TYPE
    SYNTAX      PktcRSTEDVADCBiasTableEntry
    MAX-ACCESS  not-accessible
    STATUS      current
    DESCRIPTION
        "PACM-ACCESS:NW:RO:MA
         DCbias is the signaling method to indicate the Network/E-DVA
         in/out of service state. The Operator is able to provision to
         enable planned, scheduled service times to not be signaled as
         an out of service state pending a maximum duration element.
         This data table represents the On Hook In/Out of Service parameters
         each line provided by the E-DVA.

         Each entry in this data table describes the On Hook
         In/Out of Service parameters for the associated line."
    INDEX { pktcRSTEDVALineNumber }
    ::= { pktcRSTEDVADCBiasTable 1 }

PktcRSTEDVADCBiasTableEntry ::=
    SEQUENCE {
        pktcRSTEDVADCBiasSig          TruthValue,
        pktcRSTEDVADCBiasMax          Integer32,
        pktcRSTEDVADCBiasHold         Integer32,
        pktcRSTEDVADCBiasEnable       Integer32,
        eXTOBJpktcRSTEDVADCBiasTableEntry PktcPACMExtension
    }

```

```

pktcRSTEDVADCBiasSig OBJECT-TYPE
    SYNTAX      TruthValue
    MAX-ACCESS  read-write
    STATUS      current
    DESCRIPTION
        "PACM-ACCESS:NW:RO:MA
        This data element enables/disables the DCbias management per
        provisioned values on a per telephony port basis.

        A default value of '0'(false)indicates that DCbias must
        perform per provisioned elements.

        A value of '1' (true) indicates that the DCbias is not
        controlled by the provisioned elements.

        The E-DVA MUST implement this element per the PacketCable Residential
        SIP Telephony E-DVA Specification."
    REFERENCE  "PacketCable Residential SIP Telephony E-DVA Specification"
    DEFVAL     {false}
    ::= { pktcRSTEDVADCBiasTableEntry 1 }

pktcRSTEDVADCBiasMax OBJECT-TYPE
    SYNTAX      Integer32 (0..2400)
    MAX-ACCESS  read-write
    STATUS      current
    DESCRIPTION
        "PACM-ACCESS:NW:RO:MA
        This data element specifies the maximum period of time,
        in seconds, that a DCbias must be maintained following
        an E-DVA reboot requiring a 'In-Service' State re-establishment.

        The E-DVA MUST implement this element per the PacketCable Residential
        SIP Telephony E-DVA Specification."
    REFERENCE  "PacketCable Residential SIP Telephony E-DVA Specification"
    DEFVAL     {1200}
    ::= { pktcRSTEDVADCBiasTableEntry 2 }

pktcRSTEDVADCBiasHold OBJECT-TYPE
    SYNTAX      Integer32 (0..1200)
    MAX-ACCESS  read-write
    STATUS      current
    DESCRIPTION
        "PACM-ACCESS:NW:RO:MA
        This data element specifies the period of time, in seconds,
        that a DCbias must be maintained following an Out-of-Service
        State. If the DCbiasHold duration expires, the DCbias must
        be removed from the telephony port.

        If the Network/E-DVA succeeds to re-establish the 'In-Service'
        state during the DCbiasHold duration, the DCbiasHold must be
        cancelled resulting in the DCbias being maintained on the
        telephony port in support of normal telephony signaling
        requirements.

        The E-DVA MUST implement this element per the PacketCable Residential
        SIP Telephony E-DVA Specification."
    REFERENCE  "PacketCable Residential SIP Telephony E-DVA Specification"
    DEFVAL     {600}
    ::= { pktcRSTEDVADCBiasTableEntry 3 }

pktcRSTEDVADCBiasEnable OBJECT-TYPE
    SYNTAX      Integer32 (0..60)
    MAX-ACCESS  read-write
    STATUS      current
    DESCRIPTION
        "PACM-ACCESS:NW:RO:MA

```

This data element specifies the delay time period prior to reapplying DCbias on the E-DVA telephony port following the re-establishment of the 'In-Service' state following a DCbias removal. This avoids 'race' conditions between the Network/E-DVA transitions from inappropriately signaling to the end user security system.

The E-DVA MUST implement this element per the PacketCable Residential SIP Telephony E-DVA Specification."

REFERENCE "PacketCable Residential SIP Telephony E-DVA Specification"  
DEFVAL {5}  
::= { pktcRSTEDVADCBiasTableEntry 4 }

EXTOBJpktcRSTEDVADCBiasTableEntry OBJECT-TYPE  
SYNTAX PktcPACMExtension  
MAX-ACCESS read-only  
STATUS current  
DESCRIPTION  
"PACM-ACCESS:NW:RW:OP  
Extension object for 'pktcRSTEDVADCBiasTableEntry'."  
::= { pktcRSTEDVADCBiasTableEntry 5 }

EXTOBJpktcRSTEDVADCBiasProfile OBJECT-TYPE  
SYNTAX PktcPACMExtension  
MAX-ACCESS read-only  
STATUS current  
DESCRIPTION  
"PACM-ACCESS:NW:RW:OP  
Extension object for 'pktcRSTEDVADCBiasProfile'."  
::= { pktcRSTEDVADCBiasProfile 2 }

-----  
-- MWI Signal Types  
-- Ref (PacketCable RST E-DVA Specification): MWI Signal Types  
-----

pktcRSTEDVAMWISignalTypes OBJECT IDENTIFIER ::= { pktcPACMRSTEDVAProfile 6 }

pktcRSTEDVAMWIToneInd OBJECT-TYPE  
SYNTAX TruthValue  
MAX-ACCESS read-write  
STATUS current  
DESCRIPTION  
"PACM-ACCESS:NW:RO:MA  
This is the MWI Tone Indicator.  
  
The E-DVA MUST implement this element per the PacketCable Residential SIP Telephony E-DVA Specification."  
REFERENCE "PacketCable Residential SIP Telephony E-DVA Specification"  
::= { pktcRSTEDVAMWISignalTypes 1 }

pktcRSTEDVAMWIAncInd OBJECT-TYPE  
SYNTAX TruthValue  
MAX-ACCESS read-write  
STATUS current  
DESCRIPTION  
"PACM-ACCESS:NW:RO:MA  
This is the MWI Voice Announcement Indication.  
  
The E-DVA MUST implement this element per the PacketCable Residential SIP Telephony E-DVA Specification."  
REFERENCE "PacketCable Residential SIP Telephony E-DVA Specification"  
::= { pktcRSTEDVAMWISignalTypes 2 }

```

pkcRSTEDVAMWIFSKInd OBJECT-TYPE
    SYNTAX      TruthValue
    MAX-ACCESS  read-write
    STATUS      current
    DESCRIPTION
        "PACM-ACCESS:NW:RO:MA
        This is the MWI FSK Indication.

        The E-DVA MUST implement this element per the PacketCable Residential
        SIP Telephony E-DVA Specification."
    REFERENCE  "PacketCable Residential SIP Telephony E-DVA Specification"
    ::= { pkcRSTEDVAMWISignalTypes 3 }

```

```

pkcRSTEDVAMWIDTMFInd OBJECT-TYPE
    SYNTAX      TruthValue
    MAX-ACCESS  read-write
    STATUS      current
    DESCRIPTION
        "PACM-ACCESS:NW:RO:MA
        This is the MWI DTMF Indication.
        The E-DVA MUST implement this element per the PacketCable Residential
        SIP Telephony E-DVA Specification."
    REFERENCE  "PacketCable Residential SIP Telephony E-DVA Specification"
    ::= { pkcRSTEDVAMWISignalTypes 4 }

```

```

EXTOBJpkcRSTEDVAMWISignalTypes OBJECT-TYPE
    SYNTAX      PktpACMExtension
    MAX-ACCESS  read-only
    STATUS      current
    DESCRIPTION
        "PACM-ACCESS:NW:RW:OP
        Extension object for 'pkcRSTEDVAMWISignalTypes'."
    ::= { pkcRSTEDVAMWISignalTypes 5 }

```

```

-----
-- E-DVA CODEC Provisioning
-- Ref (PacketCable RST E-DVA Specification): E-DVA CODEC Provisioning
-----

```

```

pkcRSTEDVACodecProfile OBJECT IDENTIFIER ::= { pkcPACMRSTEDVAProfile 7 }

```

```

pkcRSTEDVACodecG711Pkt OBJECT-TYPE
    SYNTAX      Integer32 (10 | 20 | 30)
    MAX-ACCESS  read-write
    STATUS      current
    DESCRIPTION
        "PACM-ACCESS:NW:RO:MA
        This data element specifies the packetization period of a
        G.711 payload.

        The E-DVA MUST implement this element per the PacketCable Residential
        SIP Telephony E-DVA Specification."
    REFERENCE  "PacketCable Residential SIP Telephony E-DVA Specification"
    DEFVAL    {20}
    ::= { pkcRSTEDVACodecProfile 1 }

```

```

pkcRSTEDVACodecT38 OBJECT-TYPE
    SYNTAX      TruthValue
    MAX-ACCESS  read-write
    STATUS      current
    DESCRIPTION
        "PACM-ACCESS:NW:RO:MA
        This data element specifies whether fax relay is enabled/disabled.
        A value of 'true' (ON) enables fax relay on the E-DVA.

        The E-DVA MUST implement this element per the PacketCable Residential

```

```

        SIP Telephony E-DVA Specification."
REFERENCE "PacketCable Residential SIP Telephony E-DVA Specification"
DEFVAL {true}
 ::= { pktcRSTEDVACodecProfile 2 }

pktcRSTEDVACodecV152 OBJECT-TYPE
SYNTAX      TruthValue
MAX-ACCESS  read-write
STATUS      current
DESCRIPTION
    "PACM-ACCESS:NW:RO:MA
    This data element specifies whether modem relay is enabled/disable.
    A value of 'true' (ON) enables modem relay on the E-DVA.

    The E-DVA MUST implement this element per the PacketCable Residential
    SIP Telephony E-DVA Specification."
REFERENCE "PacketCable Residential SIP Telephony E-DVA Specification"
DEFVAL {true}
 ::= { pktcRSTEDVACodecProfile 3 }

pktcRSTEDVACodecPubRepAddrType OBJECT-TYPE
SYNTAX      InetAddressType
MAX-ACCESS  read-write
STATUS      current
DESCRIPTION
    "PACM-ACCESS:NW:RO:MA
    This data element specifies the domain for the address
    specified in pktcRSTEDVACodecPubRepAddr. If the element
    pktcRSTEDVACodecPubRepAddr contains a valid IP address,
    this element MUST be either 'ipv4(1)' or 'ipv6(2)' per
    RFC3291. "
REFERENCE "PacketCable Residential SIP Telephony E-DVA Specification"
 ::= { pktcRSTEDVACodecProfile 4 }

pktcRSTEDVACodecPubRepAddr OBJECT-TYPE
SYNTAX      InetAddress
MAX-ACCESS  read-write
STATUS      current
DESCRIPTION
    "PACM-ACCESS:NW:RO:MA
    This data element specifies the network address that receives
    the call statistics report from the E-DVA. Publish reports must
    be sent at the end of each call if enabled.

    This address is associated with the domain specified in
    pktcRSTEDVACodecPubRepAddrType.

    The E-DVA MUST implement this element per the PacketCable Residential
    SIP Telephony E-DVA Specification."
REFERENCE "PacketCable Residential SIP Telephony E-DVA Specification"
 ::= { pktcRSTEDVACodecProfile 5 }

pktcRSTEDVACodecRTCPXR OBJECT-TYPE
SYNTAX      TruthValue
MAX-ACCESS  read-write
STATUS      current
DESCRIPTION
    "PACM-ACCESS:NW:RO:MA
    This data element specifies if extended reports for the sake of voice
    metrics are included within RTCP packets. A value of 'true' (ON)
    enables RTCP extended reports.

    The E-DVA MUST implement this element per the PacketCable Residential
    SIP Telephony E-DVA Specification."
REFERENCE "PacketCable Residential SIP Telephony E-DVA Specification"
DEFVAL {true}
 ::= { pktcRSTEDVACodecProfile 6 }
```

```

pkcRSTEDVACodecRTCPRate OBJECT-TYPE
    SYNTAX      Integer32 (0..60)
    MAX-ACCESS  read-write
    STATUS      current
    DESCRIPTION
        "PACM-ACCESS:NW:RO:MA
        This data element specifies the interval at which RTCP packets are
        sent from the E-DVA. A value of zero for RTCP_RATE disables RTCP
        transmission.

        The E-DVA MUST implement this element per the PacketCable Residential
        SIP Telephony E-DVA Specification."
    REFERENCE  "PacketCable Residential SIP Telephony E-DVA Specification"
    DEFVAL     {5}
    ::= { pkcRSTEDVACodecProfile 7 }

exTOBJpkcRSTEDVACodecProfile OBJECT-TYPE
    SYNTAX      PktpacmExtension
    MAX-ACCESS  read-only
    STATUS      current
    DESCRIPTION
        "PACM-ACCESS:NW:RW:OP
        Extension object for 'pkcRSTEDVACodecProfile'."
    ::= { pkcRSTEDVACodecProfile 8 }
-----
-- E-DVA Time Synchronization
-- Ref (PacketCable RST E-DVA Specification): E-DVA Time Synchronization
-----
pkcRSTEDVATimeProfile OBJECT IDENTIFIER ::= { pkcPACMRSTEDVAProfile 8 }

pkcRSTEDVATimeSync OBJECT-TYPE
    SYNTAX      Integer32 (0..4320)
    MAX-ACCESS  read-write
    STATUS      current
    DESCRIPTION
        "PACM-ACCESS:NW:RO:MA
        This data element specifies time synchronization interval.
        A PacketCable E-DVA must support a provisionable network time
        synchronization interval. The time synchronization interval range
        must be from 0 to 4320 hours (180 days) in increments of 1 hour.
        A provisioned value of '0' indicates the E-DVA must NOT execute
        network time resynchronization. The default network time
        synchronization interface is 48 hours.

        The E-DVA MUST implement this element per the PacketCable Residential
        SIP Telephony E-DVA Specification."
    REFERENCE  "PacketCable Residential SIP Telephony E-DVA Specification"
    DEFVAL     {48}
    ::= { pkcRSTEDVATimeProfile 1 }

exTOBJpkcRSTEDVATimeProfile OBJECT-TYPE
    SYNTAX      PktpacmExtension
    MAX-ACCESS  read-only
    STATUS      current
    DESCRIPTION
        "PACM-ACCESS:NW:RW:OP
        Extension object for 'pkcRSTEDVATimeProfile'."
    ::= { pkcRSTEDVATimeProfile 2 }
-----
-- Conformance Information
-----
pkcRSTEDVAMIBCompliances OBJECT IDENTIFIER ::= { pkcPACMRSTEDVAConformance 1
}
pkcRSTEDVAMIBGroups      OBJECT IDENTIFIER ::= { pkcPACMRSTEDVAConformance 2
}

```

```
-- Compliance Statements
pktcRSTEDVAMIBCompliance MODULE-COMPLIANCE
  STATUS current
  DESCRIPTION
    "The compliance statement for implementations of the RST EDVA Mib "
  MODULE -- this module
    MANDATORY-GROUPS {
      pktcRSTEDVAGroup
    }
  ::= { pktcRSTEDVAMIBCompliances 1 }

pktcRSTEDVAGroup OBJECT-GROUP
  OBJECTS {
    pktcRSTEDVANetDisc,
    pktcRSTEDVAAnsSup,
    pktcRSTEDVADtmfRelay,
    pktcRSTEDVAPrLossDA,
    pktcRSTEDVAPrLossAD,
    pktcRSTEDVADCBiasSig,
    pktcRSTEDVADCBiasMax,
    pktcRSTEDVADCBiasHold,
    pktcRSTEDVADCBiasEnable,
    pktcRSTEDVAMWIToneInd,
    pktcRSTEDVAMWIAncInd,
    pktcRSTEDVAMWIFSKInd,
    pktcRSTEDVAMWIDTMFInd,
    pktcRSTEDVACodecG711Pkt,
    pktcRSTEDVACodecT38,
    pktcRSTEDVACodecV152,
    pktcRSTEDVACodecPubRepAddrType,
    pktcRSTEDVACodecPubRepAddr,
    pktcRSTEDVACodecRTCPXR,
    pktcRSTEDVACodecRTCPRate,
    pktcRSTEDVATimeSync
  }
  STATUS current
  DESCRIPTION
    "The RST EDVA Group."
  ::= { pktcRSTEDVAMIBGroups 1}

pktcRSTEDVAeXTObjs OBJECT-GROUP
  OBJECTS {
    pktcPACMRSTEDVAMinorVersion,
    eXTOBJpktcPACMRSTEDVAObjects,
    eXTOBJpktcPACMRSTEDVAProfileIDs,
    eXTOBJpktcRSTEDVANetDiscTableEntry,
    eXTOBJpktcRSTEDVANetDiscProfile,
    eXTOBJpktcRSTEDVAAnsSupTableEntry,
    eXTOBJpktcRSTEDVAAnsSupProfile,
    eXTOBJpktcRSTEDVADtmfProfile,
    eXTOBJpktcRSTEDVAPrLossTableEntry,
    eXTOBJpktcRSTEDVAPrLossProfile,
    eXTOBJpktcRSTEDVADCBiasTableEntry,
    eXTOBJpktcRSTEDVADCBiasProfile,
    eXTOBJpktcRSTEDVAMWISignalTypes,
    eXTOBJpktcRSTEDVACodecProfile,
    eXTOBJpktcRSTEDVATimeProfile
  }
  STATUS current
  DESCRIPTION
    "The RST EDVA Extension Objects Group."
  ::= { pktcRSTEDVAMIBGroups 2}

END
```

## Appendix II Acknowledgements

CableLabs wishes to thank the following PacketCable focus team participants for various contributions and efforts that led to the development of this specification (in alphabetical order):

Eric Turcotte (Ericsson)

Gordon Li (Broadcom)

Harindranath P R Nair (C-Cor)

John Berg (CableLabs)

Josh Littlefield (Cisco)

Mark Trayer (Samsung)

Satish Kumar (Texas Instruments)

Thomas Clack (Broadcom)

Eric and Gordon are thanked for the RST features normalization, Thomas and Hari for the SMI and XML Schema representations respectively, Mark for the write up in Section 7, and Josh Littlefield for the PACM expert feedback.

*Sumanth Channabasappa and the PacketCable Architects, CableLabs.*